

Minuteman[®]

SCV 24/26 RIDER SCRUBBER

OPERATION ■ SERVICE ■ PARTS ■ CARE



Minuteman[®]

This manual is furnished with each new **MINUTEMAN SCV™ 24/26**. This provides the necessary operating and preventive maintenance instructions. Operators must read and understand this manual before operating or servicing this machine.

This machine was designed to give you excellent performance and efficiency. For best results and minimal cost, please follow the general guidelines below:

- Operate the machine with reasonable care.
- Follow the manufacturers suggested maintenance instructions as provided in this booklet.
- Use original Minuteman supplied parts.

TECHNICAL SPECIFICATIONS

Model	SCV™ 24/26
Model #	SC240000QP \ SC240001QP SC260000QP \ SC260001QP
Current	52 Amps
Voltage, Batteries	36 volts, 3-12volt
Battery Capacity	210 AH
Sound Level	71dB
Dimensions (LxWxH)	60" x 23" x 53" (152.4cm x 58.42cm x 134.62cm)
Gross Weight	1,027 lbs (466 kg) with batteries 637 lbs (289 kg) without batteries
Working Grade Transport	16% (10°)
Wheel to Floor Pressure	61 PSI Front, 67 PSI Rear

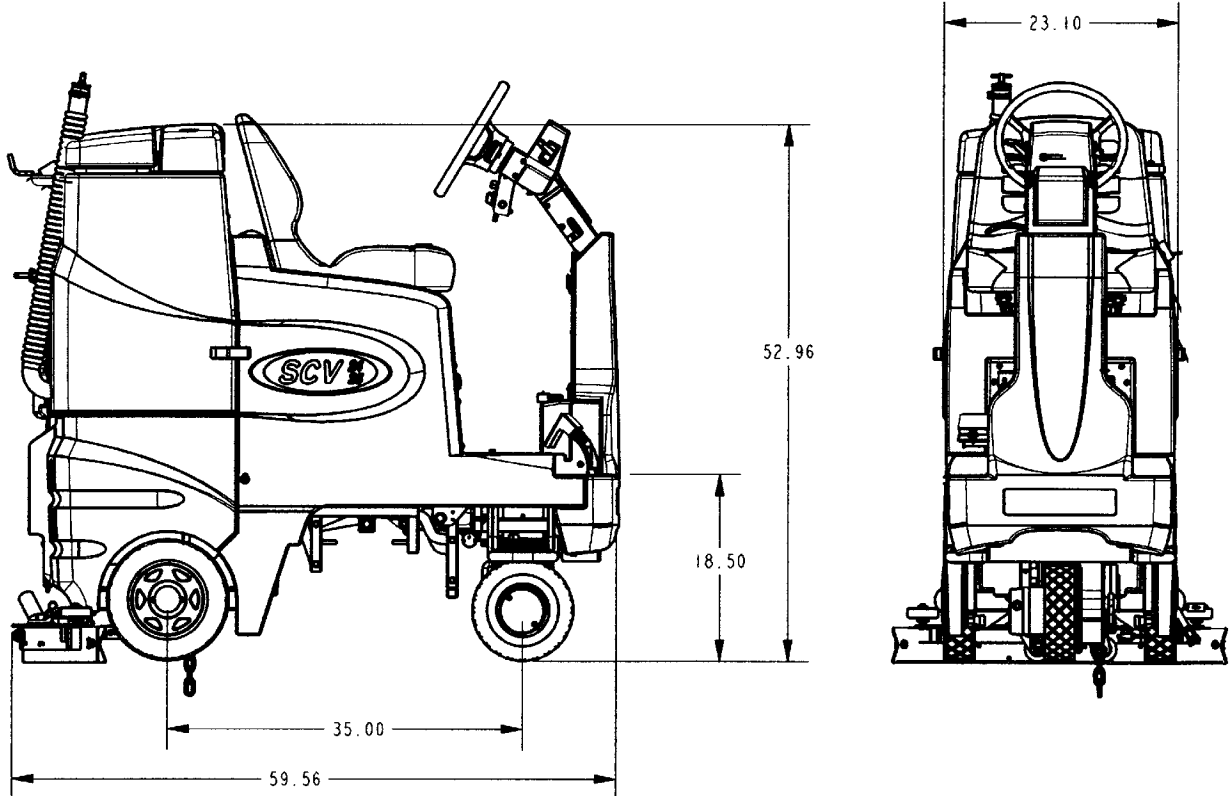

EC Declaration of Conformity

according to Directives 98/37/EC, 89/336/EEC and 72/23/EEC

We, Minuteman International Incorporated, of 111 South Rohlwing Road Addison Illinois 60101 USA, declare under our sole responsibility that the product SC240000CE, SC240000QPIW, SC240001QPIW, SC240001CE, SC260000QPIW, SC260001QPIW, SC260000CE, SC260001CE Automatic Floor Scrubbing machines to which this declaration relates corresponds to the relevant requirements of the EC Directives 98/37/EC, 89/336/EEC and 72/23/EEC. The following standards were used to determine compliance with the Directives: EN 292, EN 60335-2-72, EN 953, EN 55022:1998 AND EN 60335-1:2002.

SOUND		VIBRATION						
71 dB Operator	68 dB At 3m	1.9 m/s² At Operators Hand Grips						
Tests were conducted on 11/11/04 with calibrated sound and vibration equipment under the conditions noted below: <table style="width: 100%; margin-top: 10px;"> <tr> <td style="width: 50%;">General Condition: Cloudy</td> <td style="width: 50%;">Wind: 0 km/hr</td> </tr> <tr> <td>Temperature: 28⁰C</td> <td>Humidity: 85%</td> </tr> <tr> <td>Barometric Pressure: 29.5</td> <td></td> </tr> </table>			General Condition: Cloudy	Wind: 0 km/hr	Temperature: 28 ⁰ C	Humidity: 85%	Barometric Pressure: 29.5	
General Condition: Cloudy	Wind: 0 km/hr							
Temperature: 28 ⁰ C	Humidity: 85%							
Barometric Pressure: 29.5								

Jeff Pollack

11/11/04

Jeff Pollack, Standards Engineer

Date

Form: EC080 RevA

TABLE OF CONTENTS
Operation, Illustrations, Spare Parts, and Maintenance

IMPORTANT SAFETY INSTRUCTIONS 4

FOR SAFETY DURING OPERATION:..... 4

FOR SAFETY WHEN SERVICING OR MAINTAINING MACHINE: 4

 INSPECTION6

 ELECTRICAL.....6

 BATTERIES6

 OPERATOR RESPONSIBILITY6

MACHINE OVERVIEW - FRONT 7

MACHINE OVERVIEW - REAR 8

LOWER CONTROL CONSOLE 9

 1. REGULAR SCRUB MODE9

 2. HEAVY SCRUB MODE9

 3. DOUBLE SCRUB MODE.....9

 4. VACUUM ONLY MODE.....10

 5. TRANSPORT MODE10

 6. SOLUTION CONTROL.....10

UPPER CONTROL CONSOLE 11

 EMPTY SOLUTION TANK INDICATOR11

 LOW BATTERY INDICATOR11

 STEERING WHEEL.....11

OPERATION OF CONTROLS 12

 POWER SAVE MODE12

 ACCELERATOR PEDAL12

 SEAT12

 DIRECTIONAL SWITCH.....12

 PARKING BRAKE.....13

 EMERGENCY DISCONNECT BUTTON13

 CIRCUIT BREAKERS.....13

 BATTERY COMPARTMENT13

SCRUB DECK 14

CYLINDRICAL SCRUB DECK..... 14

 SCRUB DECK SHIFT15

 SCRUB DECK INSTALLATION.....16

INSTALLATION INSTRUCTIONS 16

SIDE SQUEEGEE 17

REAR SQUEEGEE..... 19

 REAR SQUEEGEE ADJUSTMENT20

 OFF-AISLE WAND (Optional)21

 OFF-AISLE WAND TOOL (Optional).....21

THE SCV RIDER 22

MACHINE OPERATION..... 22

MAINTENANCE SCHEDULE..... 25

GENERAL MACHINE TROUBLESHOOTING.....	26
SCV 24/26 FAULT / DIAGNOSTIC CODES	28
EXPLODED VIEWS	29
MAIN ASSEMBLY I.....	29
MAIN ASSEMBLY II	30
MAIN ASSEMBLY BOM (SEE MAIN ASSEMBLY I & II).....	31
MAINFRAME ASSEMBLY	32
LINKAGE ASSEMBLY	33
LINKAGE ASSEMBLY BOM.....	34
FRONT DRIVE ASSEMBLY	35
STEERING ASSEMBLY I.....	37
STEERING ASSEMBLY II.....	38
SOLUTION TANK ASSEMBLY I	40
SOLUTION TANK ASSEMBLY II.....	41
SOLUTION TANK ASSEMBLY BOM (SEE SOL. TANK ASSY I & II)	42
SEAT ASSEMBLY.....	43
RECOVERY TANK ASSEMBLY I.....	45
RECOVERY TANK ASSEMBLY II	46
PUMP ASSEMBLY	48
PUMP ASSEMBLY BOM.....	49
REAR AXLE ASSEMBLY	50
SQUEEGEE MECHANISM ASSEMBLY	51
REAR SQUEEGEE ASSEMBLY	52
BATTERY PANEL ASSEMBLY (LEFT HAND SIDE)	53
24” CYLINDRICAL SCRUB DECK ASSEMBLY I (ITEMS 1 – 35)	55
24” CYLINDRICAL SCRUB DECK ASSEMBLY II (ITEMS 36 – 65).....	56
24” CYLINDRICAL SCRUBDECK BOM (SEE ASSEMBLY I & II)	57
26” CYLINDRICAL SCRUB DECK ASSEMBLY I (ITEMS 1 – 35)	58
26” CYLINDRICAL SCRUB DECK ASSEMBLY II (ITEMS 36 – 65).....	59
26” CYLINDRICAL SCRUBDECK BOM (SEE ASSEMBLY I & II)	60
24” DISC SCRUB DECK ASSEMBLY I	61
24” DISC SCRUB DECK ASSEMBLY II.....	62
24” DISC SCRUB DECK BOM (SEE ASSEMBLY I & II)	63
26” DISC SCRUB DECK ASSEMBLY I	64
26” DISC SCRUB DECK ASSEMBLY II.....	65
26” DISC SCRUB DECK BOM (SEE ASSEMBLY I & II)	66
CYLINDRICAL SIDE SQUEEGEE (LEFT SIDE)	67
CYLINDRICAL SIDE SQUEEGEE (LEFT SIDE)	67

CYLINDRICAL SIDE SQUEEGEE (RIGHT SIDE)	68
DISK SIDE SQUEEGEE (LEFT SIDE)	69
DISC SIDE SQUEEGEE (RIGHT SIDE)	70
24" CYLINDRICAL BRUSH ASSEMBLY	71
24" DISC BRUSH ASSEMBLY	72
26" CYLINDRICAL BRUSH ASSEMBLY	73
26" DISC BRUSH ASSEMBLY	74
OFF AISLE WAND ASSEMBLY BOM (OPTIONAL)	76
PLUMBING DIAGRAM	77
WIRING DIAGRAMS	78
LIMITED WARRANTY	82

IMPORTANT SAFETY INSTRUCTIONS

Operators must read and understand this manual before operating or maintaining this machine.

Do not operate this machine in flammable or explosive areas.

This machine is designed solely for scrubbing dirt and dust in an indoor environment. Minuteman does not recommend using this machine in any other capacity.

The following information below may cause a potential hazard to the operator and equipment. Read this manual carefully and be aware when these conditions can exist. Take necessary steps to locate all safety devices on the machine and train the personnel operating the machine. Report any machine damage or faulty operation immediately. **Do not use machine if it is not in proper operating condition.**

FOR SAFETY DURING OPERATION:

Keep hands and feet clear of moving parts while machine is in operation.

Make sure all safety devices are in place and operate properly. All covers, doors and latches must be closed and fastened before use.

During operation, attention should be paid to other persons in the work area and especially if small children are present.

Electric motors and components can cause an explosion when operated near explosive materials or vapor. Do not operate this machine near flammable materials such as solvents, thinners, fuels, grain dust, etc.

Store or park this machine on a level surface only. To prevent unauthorized use, machine should be stored or parked with the key removed.

This machine is designed for level operation only. **Do not operate on ramps or inclines.**

This machine is not suitable for picking up hazardous dusts.

Use caution when moving this machine into areas that are below freezing temperatures. Any water in the tanks or hoses can cause damage to the machine.

FOR SAFETY WHEN SERVICING or MAINTAINING MACHINE:

Stop on level surface.

Disconnect the power to the machine by pressing the Red Emergency Disconnect Button when charging batteries or during installation or removal of brushes.

Avoid moving parts. Do not wear loose jackets, shirts, or sleeves when working on machine.

Avoid contact with battery acid. Battery acid can cause burns. When working on or around batteries, wear protective clothing and safety glasses. Remove metal jewelry. Do not lay tools or metal objects on top of batteries.

Charging batteries generates explosive gasses. **Do not charge batteries when open flames or sparks are present. Do not smoke.** Make sure the charger is turned off before disconnecting it from the machine.

Charge the batteries in a well-ventilated area with the battery cover removed completely.

Do not clean machine with a pressure washer.

Authorized personnel must perform repairs and maintenance. Use Minuteman supplied replacement parts.

SAVE THESE INSTRUCTIONS

INSPECTION

Carefully unpack and inspect your **SCV Rider Scrubber** for shipping damage. Follow unpacking instructions on shipping pallet. Each unit has been tested and thoroughly inspected before shipment. Any damage is the responsibility of the delivery carrier who should be notified immediately.

ELECTRICAL

This machine is battery operated and designed to operate on 36 volts DC (3) 12-volt batteries.

BATTERIES

The recommended batteries are rated 210Ah (Minuteman P/N 956210).

We do not recommend mixing AMP hour capacities. Any alternate battery sets can be used if they equal physical size and capacity.

OPERATOR RESPONSIBILITY

Read this manual carefully before operating this machine.

The operator is responsible in taking care of the daily maintenance and check ups of the machine to keep it in good working condition. The operator must inform the service mechanic or supervisor when the scheduled maintenance intervals are required as stated in the *MAINTENANCE* section of this manual.

Before starting familiarize yourself with the machine and its controls (see “Machine Overview, Front”, “Machine Overview, Rear”, “Operator Compartment”, “Control Console” diagrams).

MACHINE OVERVIEW - FRONT

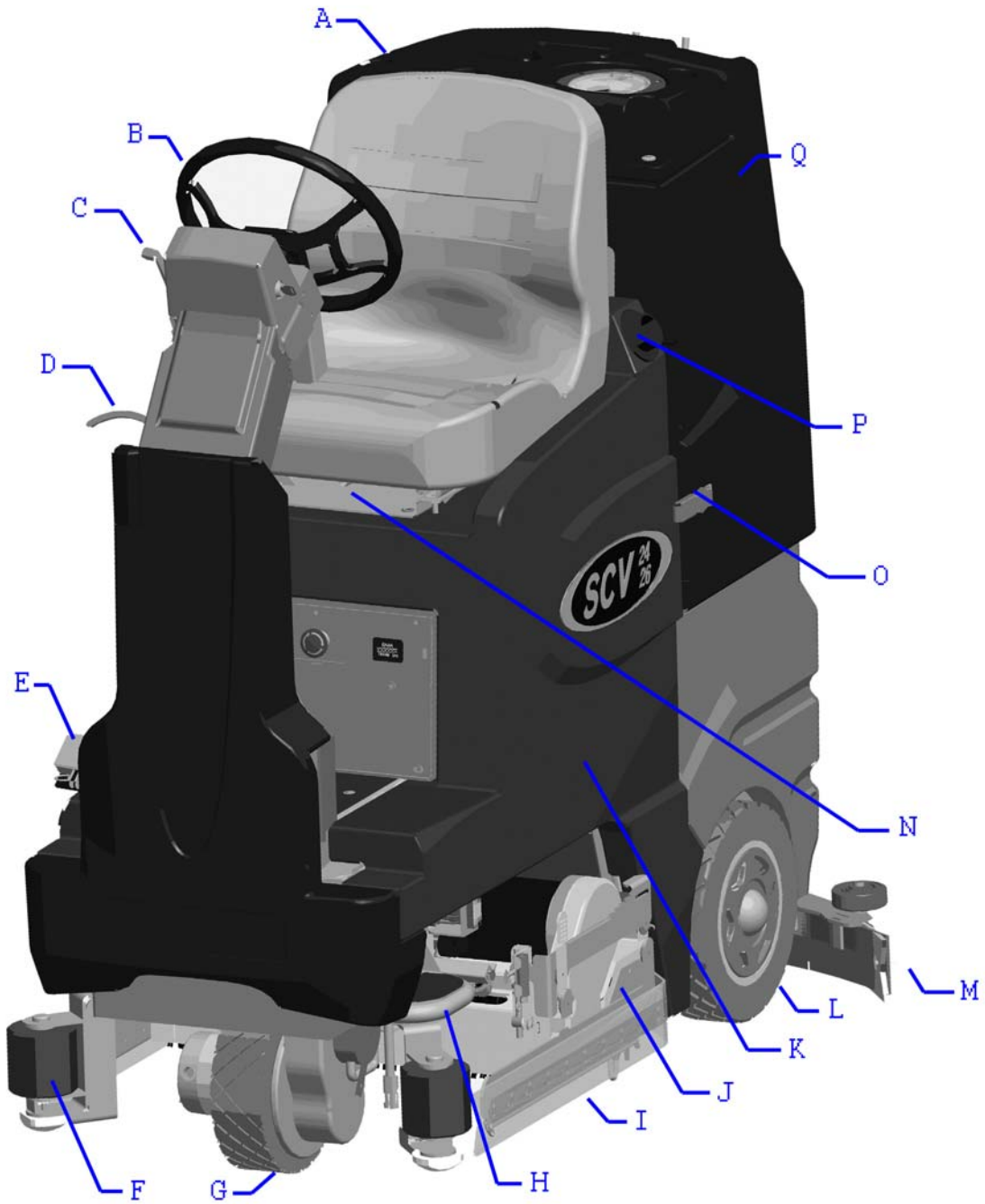

A	Recovery Tank Lid	G	Front Drive Wheel	M	Rear Squeegee
B	Steering Wheel	H	Foot Step	N	Seat Adj. Lever
C	Directional Lever	I	Side Squeegee	O	Safety Latch
D	Tilt Steering Lever	J	Scrub Deck	P	Solution Tank Fill Port
E	Accelerator Pedal	K	Solution Tank	Q	Recovery Tank
F	Roller Bumper	L	Rear Wheel		

MACHINE OVERVIEW - REAR

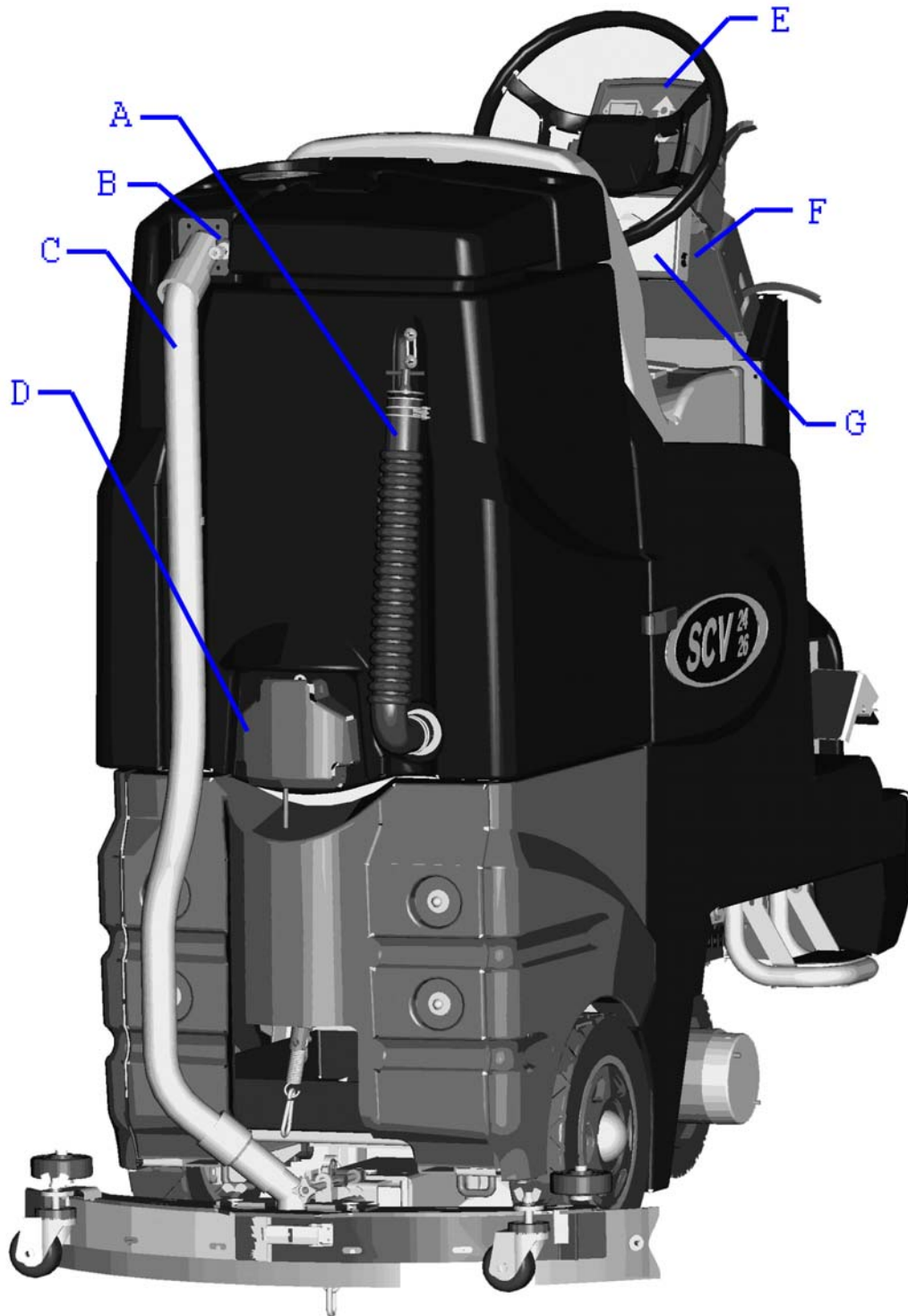

A	Recovery Tank Dump Hose	E	Upper Control Console
B	Off Aisle Wand Hose Connection	F	Horn
C	Recovery Hose	H	Lower Control Console
D	Cleanout		

LOWER CONTROL CONSOLE

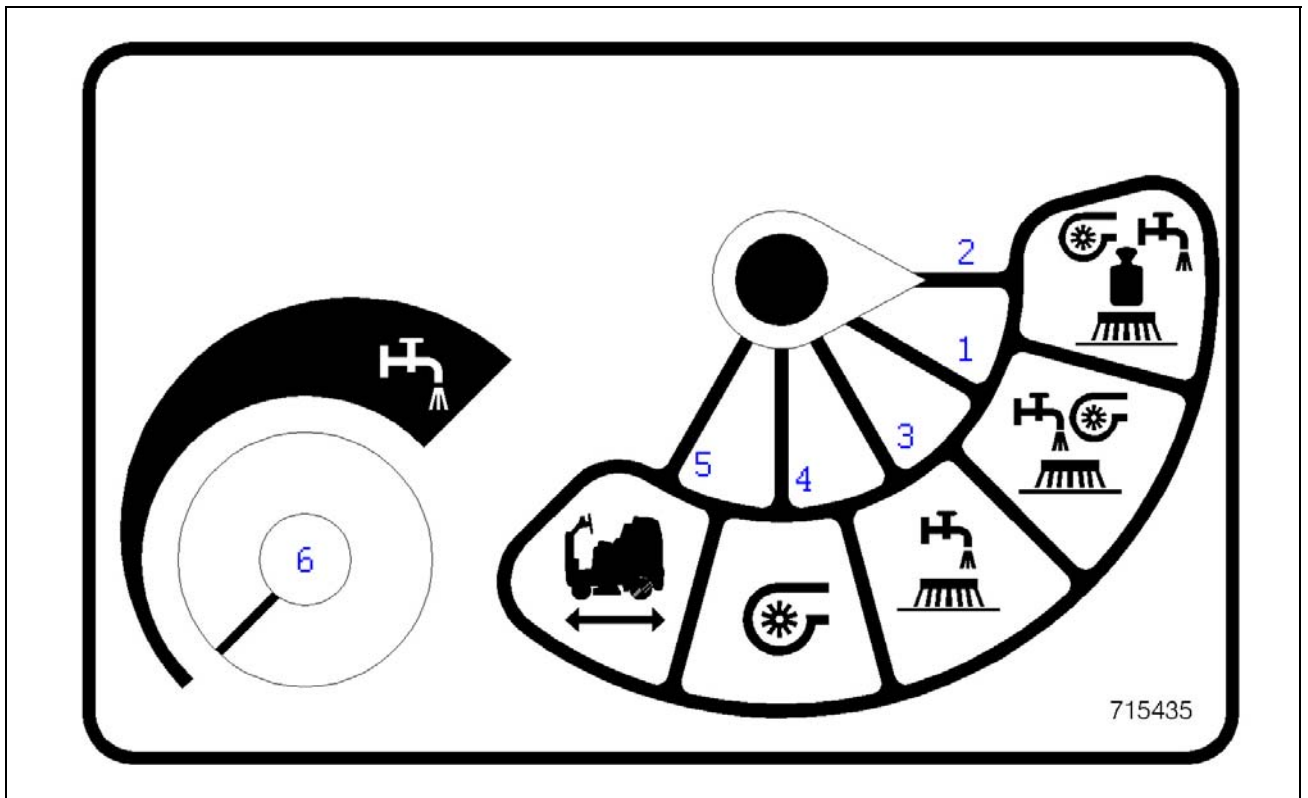

1. REGULAR SCRUB MODE

When the machine is running in this mode, the machine will perform all operations. This mode can be used for day-to-day tasks under normal conditions. When the operator sets the *directional switch* to *forward* and activates the *accelerator handle*, the solution pump will turn on, the brushes will turn on and be lowered to the floor, as well as the rear squeegee. While operating in this mode, the solution will be dispersed into the brushes, which will scrub the floor allowing the chemical in the solution to break down the dirt on the floor. As the machine continues to move forward, the rear squeegee and vacuum system will recover the dirt and dispensed solution. If the operator stops moving, the machine will automatically raise the scrub deck and turn off the brushes. If the *directional switch* is changed to reverse the machine will continue to operate normally, only the rear squeegee will raise up.

2. HEAVY SCRUB MODE

This mode is similar to *Regular Scrub*. The machine will continue to operate the same as if it was in *Regular Scrub Mode*, only this mode applies more solution and brush pressure is increased. This mode is used for high traffic areas and areas that have been heavily soiled, but do not require time for the solution to soak.

3. DOUBLE SCRUB MODE

When the machine is running in this mode, the machine will perform all operations except dirty solution recovery. This mode can be used if the floor is heavily soiled and the chemical

will need additional time to emulsify grease and oils that are on the floor. When the operator sets the *directional switch* to either the *forward* or *reverse* position and activates the *accelerator lever*, the solution pump will turn on, the brushes will turn on and be lowered to the floor. While operating in this mode, the solution will be dispersed into the brushes, which will scrub the floor allowing the chemical in the solution to break down the dirt on the floor. As the machine continues to move forward or back, the rear squeegee and vacuum system are not on, which allows the solution to stay on the floor emulsifying the grease and oil. If the operator stops moving in either direction, the machine will automatically raise the scrub deck and turn off the brushes. After double scrubbing, the operator should use *the vacuum only mode* to recover the dirty solution water from the floor.

4. VACUUM ONLY MODE

When the machine is running in this mode, the machine will only lower the rear squeegee and turn on the vacuum system to recover the dirty solution from the floor. This mode is usually chosen after double scrubbing to recover the dirty solution but it can also be used to pick up spills. When the operator sets the *directional switch* to *forward*, the rear squeegee will be lowered to the floor as the vacuum turns on, pulling the dirty solution water from the rear squeegee into the recovery tank. If the operator stops moving forward and sets the directional switch to *reverse*, the rear squeegee will retract (protecting it from damage) and the vacuum motor will turn off after a few seconds. If the operator quits moving in either direction, the machine will automatically raise the squeegee and turn off the vacuum motor after a few seconds.

5. TRANSPORT MODE

When the machine is set in this mode, none of the cleaning functions of the machine will operate. This mode is only used to transport the machine from one location to another at a faster rate of speed.

6. SOLUTION CONTROL

This control will adjust the amount of solution that is being dispersed to the floor while in one of the scrub mode. Adjust control clockwise to increase the amount of solution being dispersed. The solution distribution range is from zero (0) to a maximum of $\frac{3}{4}$ GPM.

UPPER CONTROL CONSOLE

EMPTY SOLUTION TANK INDICATOR

Once the solution tank has become empty the battery gauge will blink a solid 9 LEDs at a constant interval to alert the driver that the solution tank needs to be filled.

LOW BATTERY INDICATOR

The battery gauge bar icon will be flashing to signal the operator that the machine is almost out of power. Once this signal is displayed to the operator, all functions will shut off including the transport mode. The operator has to turn the *key switch OFF and then, ON* to reset the machine. The machine then will only have a few minutes left of reserve power for a short *Vacuum only mode* to pick up remaining solution on the floor and *Transport* power.

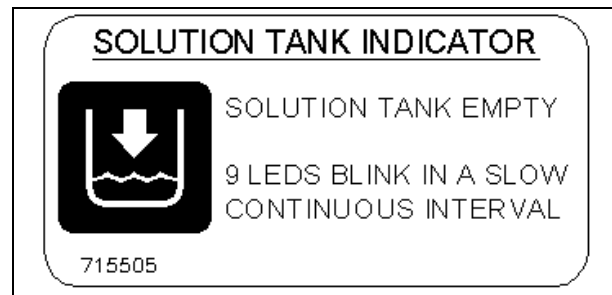

STEERING WHEEL

The steering wheel is adjustable for operator comfort by pulling the *tilt-steering lever* up and positioning the steering wheel up or down (there are three possible positions). By pulling on the *tilt-steering lever* and positioning the steering column in an upright fashion, enables the operator more room when climbing up and down the machine.



OPERATION OF CONTROLS

POWER SAVE MODE

The SCV is equipped with a power save feature to conserve battery power. If the key switch power is left ON and none of the controls are activated for a period of fifteen minutes, the SCV automatically goes into “power down mode” and turns OFF the power to conserve your batteries in case the operator forgets to turn the key switch off or leaves the machine unattended.

ACCELERATOR PEDAL

Located on the right side of the operator compartment on the floor is the accelerator pedal. This pedal controls the propelling speed of the machine. The farther the pedal is pushed down the faster the machine will travel. As discussed earlier, the directional switch governs the direction of travel the machine will take. Switching the directional switch with your foot pushed on the pedal will make your machine change directions (a very slight delay may occur before the direction of travel changes when switching directions on the fly). The accelerator pedal is interlocked with the seat switch, making machine propulsion not possible without the operator sitting on the seat.

SEAT

The ergonomically designed seat is located on top of the solution tank. There is a lever under the seat that allows the operator to adjust the seat forward or backward for operator comfort. There is an interlock switch located inside the seat. This makes it impossible to engage the traction drive circuitry without the operator on the seat. If the operator were to fall off the machine, the traction drive circuitry would turn off.

DIRECTIONAL SWITCH

Located on the right side of the *upper control console*, this switch controls the direction in which the SCV will move when the *accelerator pedal* is activated. There are two arrows located on the *upper control console* with LEDs in the center to indicate which mode the SCV is in. The arrow pointing forward with the amber LED indicates the SCV is in forward mode. The arrow pointing backward with the red LED indicates the SCV is in reverse mode.

PARKING BRAKE

This machine is equipped with an *Electro-magnetic brake* built-in on the traction drive motor. When the machine's power is turned off (using either the key or the emergency button), the *E-mag* brake is activated and the traction motor is prevented from moving.

EMERGENCY DISCONNECT BUTTON

This button is located in the middle of the electrical panel that is directly underneath the operator's seat. When the *red* emergency button is pressed, power will be turned off. Use this button in case of a machine emergency. The red knob needs to be raised in order to run the machine. To reactivate, turn the knob as shown by the arrow on the switch and the button will pop up. *All operational settings are retained even when the power is turned off and on.*

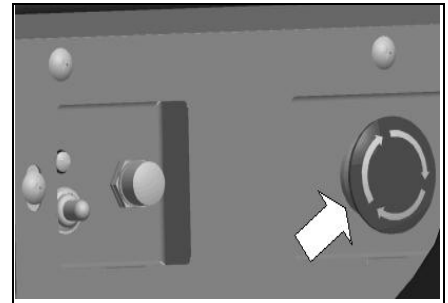

CIRCUIT BREAKERS

The circuit breakers are located next to the emergency disconnect button. The **6-amp breaker** (indicated by white arrow). This breaker protects all auxiliary circuits on the machine (headlights, horn, and back-up alarm). The **100-amp breaker** (indicated by black arrow) protects the main system circuit (controller). Each main component is individually protected with an internal breaker built-in the controller. (See fault code table) and can be reset by turning the key switch off a few seconds and then on again. The 100 amp circuit breaker can also be used as a main power disconnect, this should be used only in case of emergency. When tripped the breaker removes power from the main controller and all auxiliary power circuits

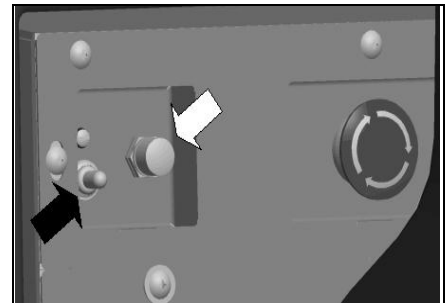

BATTERY COMPARTMENT

The battery compartment is located on the rear of the machine under the recovery tank. Unlatching the two safety latches on the side of the machine enables the operator to tilt the recovery tank and access the batteries for servicing and maintenance (make sure recovery tank has been drained before tilting). The battery compartment contains three 12-volt batteries connected in series. Connect the batteries according to the battery connection diagram (*see diagram*). The recommended batteries are 210Ah (Minuteman P/N 956210).

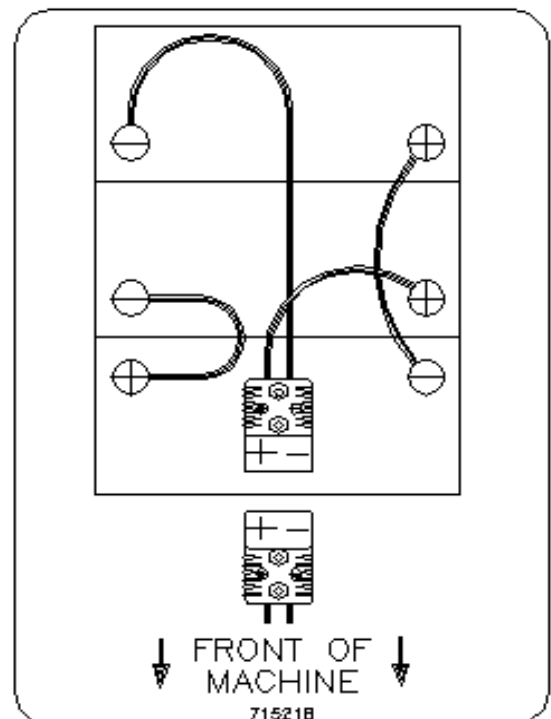

SCRUB DECK

Minuteman offers two deck types (*Cylindrical and Disc*) to fit your specific needs. The SCV design is very dynamic wherein the decks are interchangeable in a matter of minutes whenever necessary (removal of four bolts, and two quick-connects). The *cylindrical brush deck* has four built-in spray jets to uniformly dispense cleaning solution on the floor and a wet sweeping debris tray to collect loose objects on the floor. *The disc brush deck* dispenses cleaning solution through the center hub and contained within the bristle area for efficient agitation of cleaning solution to the floor and channeled to the rear of the machine. The disc brushes are also easily removed and installed with the quick release clamp by using any of the three access doors. Another nice feature that these scrub decks have is the ability to have uniform brush pressure applied to the floor at all times. Since the scrub deck brush pressure is computer controlled, it will automatically adjust and compensate to uneven contours on the floor while maintaining brush pressure.

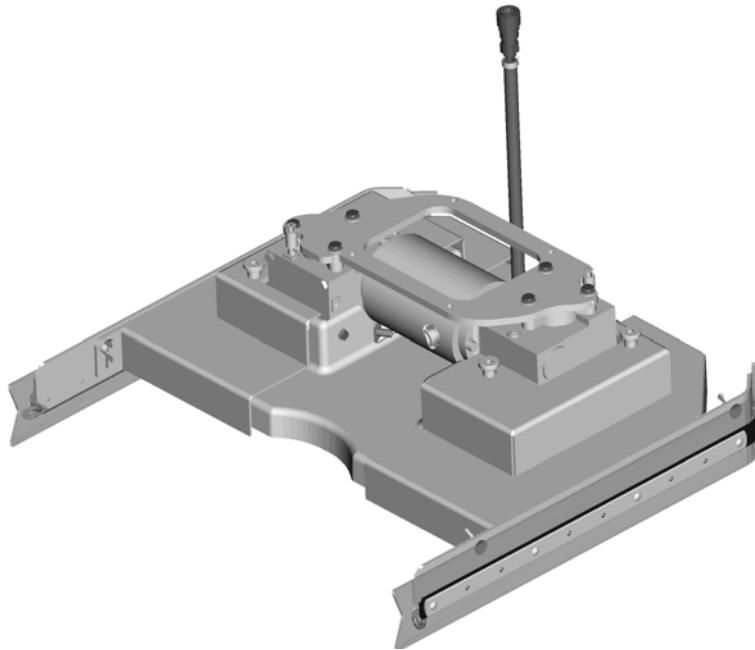

Disc Scrub Deck

Cylindrical Scrub Deck

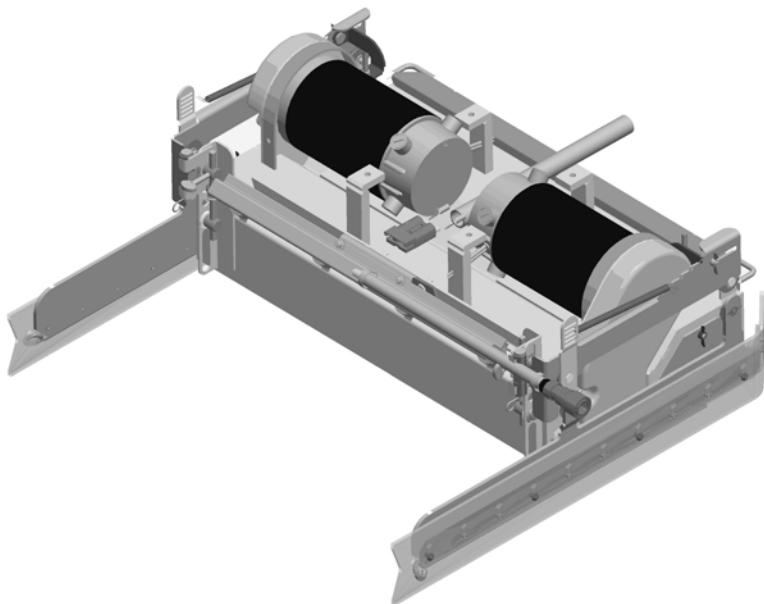

SCRUB DECK SHIFT

The SCV 2426 now incorporates the new side shift feature, which allows the scrub deck to move two inches to the right to allow users to get into tighter quarters such as under shelving or cleaning close to walls.

The side shift is activated by a lighted three-position rocker switch located directly in front of the drivers seat, just below the steering wheel (See figure below). The 3 position switch has 3 main functions, return (1), stop (2) and right offset (3). In order to move the deck right, ‘click’ the switch from the stop position to the right offset position, you may choose to ‘click’ stop at any time for an arbitrary side shift, otherwise the deck will achieve it’s full two inch side shift. In order to return the deck to its original position ‘click’ the switch to the return position.

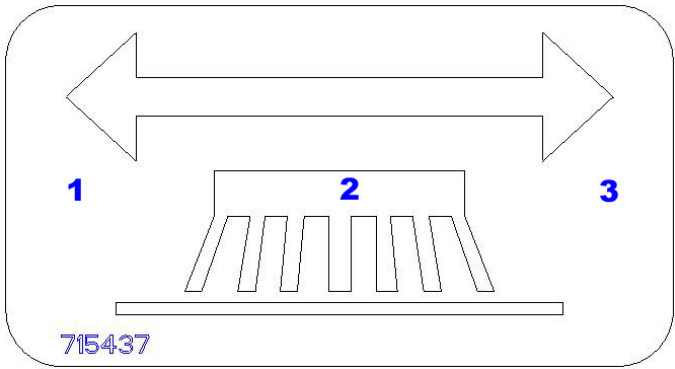

Detailed view of 3-Position Switch



Location of Side Shift Switch

SCRUB DECK INSTALLATION

When installing a cylindrical deck to a machine:

1. Install brushes **after** the deck has been mounted to avoid flat spots on the brushes.
2. Use a piece of cardboard underneath the deck to prevent scratches to the painted surface when sliding the deck under the machine.
3. Make sure the scrub deck is oriented correctly with the spray jets towards the front of the machine.

When installing a disc scrub deck to a machine:

1. Install brushes on the scrub deck; this aids the installer in sliding the deck assembly into position.
2. Make sure the scrub deck is oriented correctly with the solution hose tee fitting towards the front of the machine.

INSTALLATION INSTRUCTIONS

1. Park the machine on a flat or level surface.
2. Turn the key switch to the ON position and select the transport mode on keyboard.
3. Slide the scrub deck assembly underneath the machine (follow instructions as described above)
4. Position the scrub deck to align the mounting brackets with the mounting lugs on the lift linkage.
5. Lower the lift linkage to the floor by pressing the manual override switch for five seconds.

Manual Override Switch.
Located under front left side of machine.

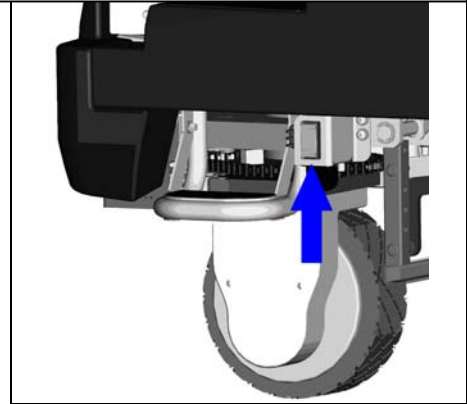

6. Lower the lift linkage mounting lugs until they barely touch the scrub deck mounting brackets.
7. Fasten with the four (4) 711242 bolts, 711515 flat washer and 711546 lock washer.
8. For cylindrical scrub deck only:

- a. Remove wing nut on side squeegee assembly and swing out side squeegee to access door.
- b. Remove the two access doors (one each end) by removing the (3) nyloc nuts.
- c. Install the brushes by sliding through the access opening. (See Figure 1 for correct orientation)
- d. Align the notches on the brush with the drive pins on the hub.
- e. Push brush all the way until it bottoms out.
- f. Insert access door hub to the other end of brush.
- g. Reinstall nuts and tighten.

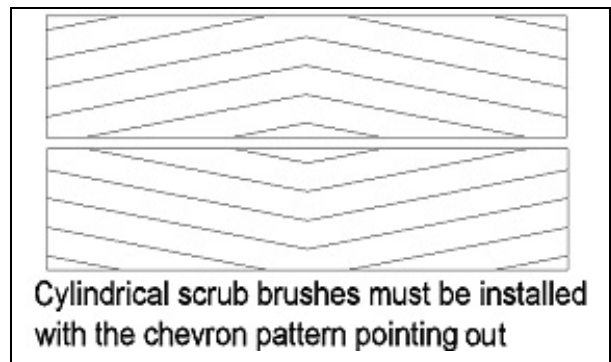

SIDE SQUEEGEE

The side squeegees (left and right) are attached to the scrub decks. These items channel the dirty solution to the rear squeegee, helping contain the water within the machine's cleaning path. These squeegees are raised when the scrub deck is in the raised position.

The side squeegees are pre-adjusted at the factory. Adjustments may be required when replacing worn blades or to achieve optimum performance for different floors and conditions.

To adjust the side squeegees, simply loosen the two (front and back) wing nuts (item 1) located behind the side squeegee blades. Lower the scrub deck by switching to a scrubbing mode and when the brushes start up, turn off the key switch. At this point the side squeegees should be resting vertically (no deflection) on the floor. Press down on the side squeegee bracket assembly from each end while making sure that the blade is uniformly deflected in a 45 degree angle along its whole length. Tighten the wing nuts. Turn the steering wheel all the way to the left or right and start pushing the machine to the side to inspect the blade deflection and wiping action. Repeat the steps above until a satisfactory result is obtained. (See the following page for the location of the wingnuts on the cylindrical deck, marked Item 1).

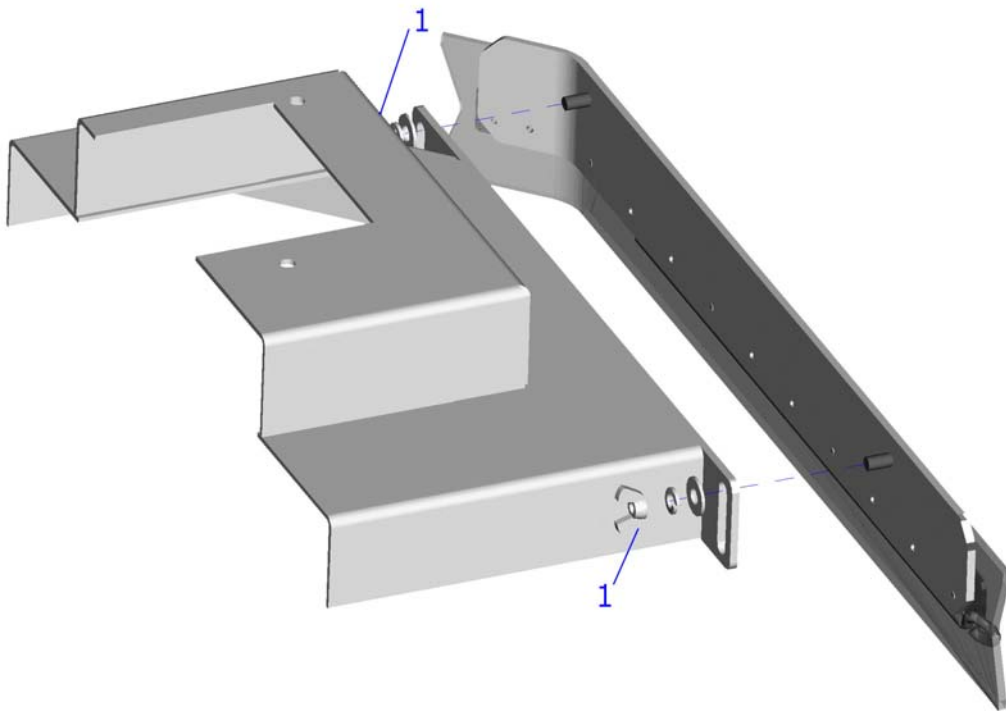

Brush Changes on the Cylindrical Deck

In order to change the brushes on the cylindrical deck the side squeegee must be moved in order to access the brush doors. The cylindrical deck was designed so one can change the brushes without having to realign the side squeegees. This is accomplished by removing a wingnut (Item 2) and swinging the squeegee along the hinge bracket located at the front of the deck, gaining access to the brushes. Once completed inserting new brushes, replace the brush doors and swing the squeegee back into place, tightening down the wingnut (item 2).

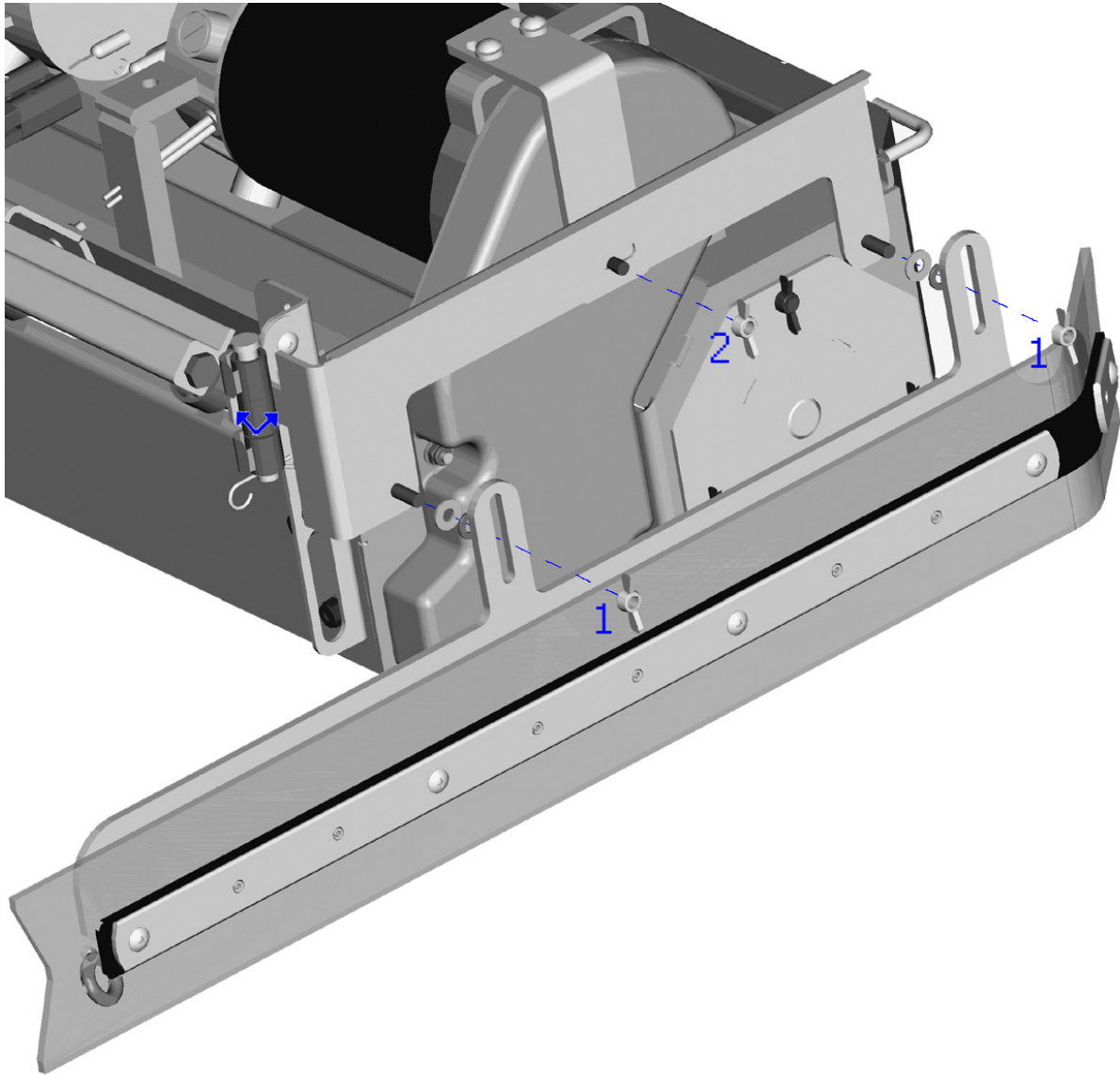

REAR SQUEEGEE

The rear squeegee is the main element that acts as the conduit that transfers the spent solution into the recovery tank. A daily maintenance check of this component is essential to have optimum machine performance. The rear squeegee assembly is equipped with a universal front blade that allows the operator the option to use a slotted and a non-slotted side for specific applications. Each blade configuration has two usable edges. The rear blade however has four usable edges.

The squeegee is pre-adjusted at the factory. Adjustments may be required to get optimum performance for different floors and conditions.

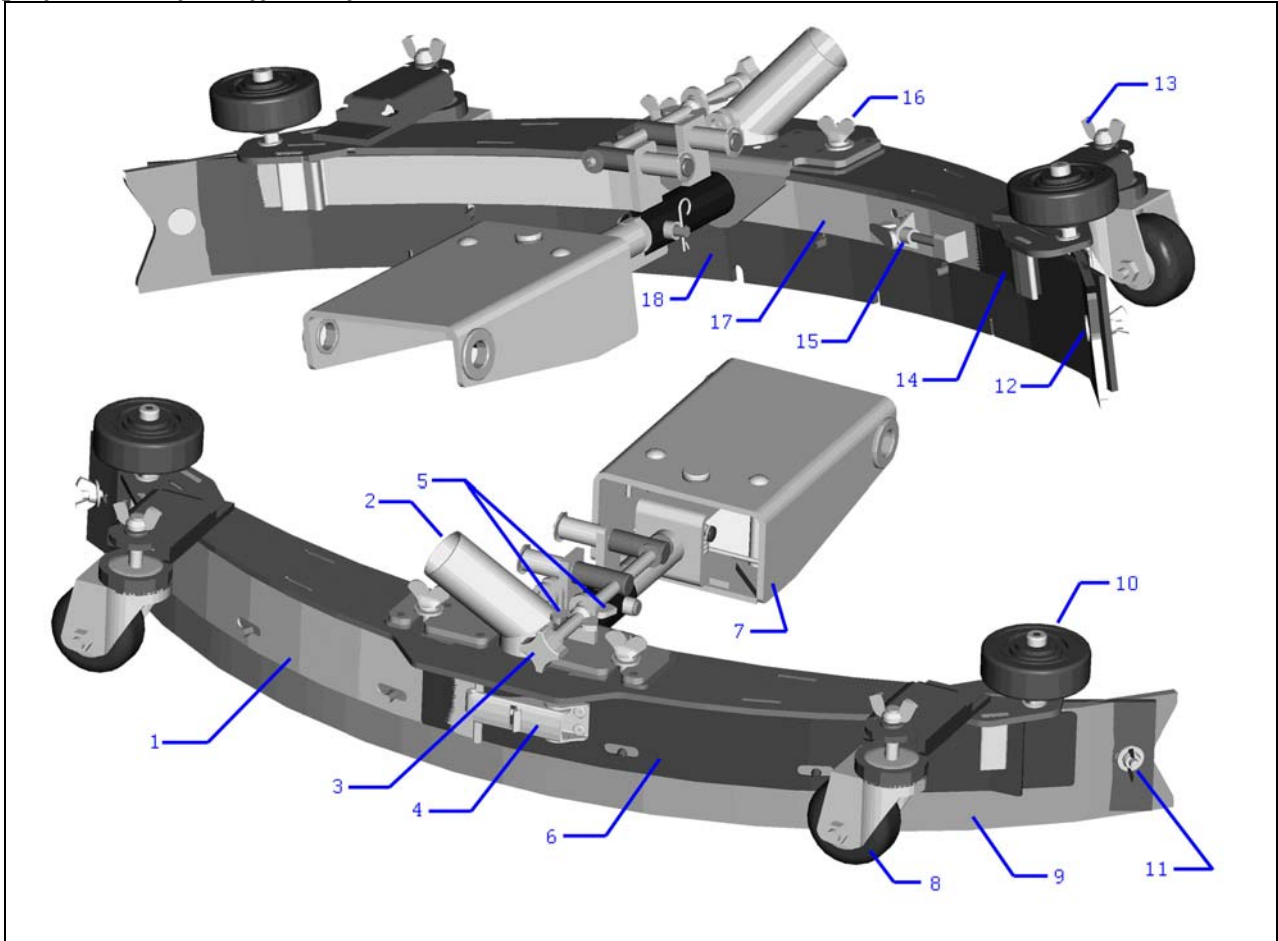

1	Rear Strap (catch side)	10	Guide Wheel
2	Recovery Hose Intake	11	Nylon Wing Nut
3	Pitch Adj. Knob	12	Nylon Bolt
4	Latch	13	Wing Nut
5	Wing Nut	14	Front Strap (short)
6	Rear Strap (latch side)	15	Toggle Clamp
7	Turnbuckle	16	Wing Bolt
8	Caster	17	Front Strap (long)
9	Rear Squeegee Blade	18	Wiper Blade

REAR SQUEEGEE ADJUSTMENT

1. Ensure that the scrubber is on a relatively flat surface. Turn on the key switch and select the *Vacuum only* mode. This lowers the squeegee to the floor and turns the vacuum motor on.
2. Move the scrubber one or two feet forward slowly while someone behind the machine checks the rear squeegee blade (item **1**) for uniform deflection to the floor.
3. If uneven deflection or lay is evident, minor adjustments may be necessary to avoid streaking and uneven wear on the blade.
4. To correct this, loosen the wing jam nut (item **12**) in order to adjust the caster height. If the squeegee blade is deflecting too much, the casters (item **8**) need to be lowered to control the down pressure. Lower the caster by turning the exposed threaded stem on the caster clockwise. Make the adjustment a few turns at a time. **Repeat step 2.**
5. If the blades are not deflecting enough, raise the caster by turning the stem counter-clockwise to adjust the caster height to allow more down pressure on the squeegee. **Repeat step 2.**
6. Make sure there is even deflection on the entire length of the rear blade. Adjust the casters and retighten the wing jam nuts to lock the caster setting in place.
7. Pitch adjustment is necessary if the outer ends on the squeegee blade do not contact the floor and there is too much deflection in the middle area or if the outer ends are over deflected and there is no contact in the middle.
8. To adjust the pitch, Repeat step 2.
9. Loosen the two wing nuts (item **5**) that lock the pitch angle. Turning the knob (item **3**) clockwise or counter-clockwise controls the forward and backward pitch of the squeegee. Having the rear blades deflected uniformly along its entire length is the desired set-up.
10. Repeat step 2 until desired set-up is achieved.
11. In certain applications where a non-slotted front wiper blade (item **18**) is needed, detach the rear squeegee assembly by loosening the two wing bolts (item **16**). Unlock the toggle clamp (item **15**) on the front squeegee to release the front long strap (**17**) and slide the front short strap (item **13**). Flip the blade over to the non-slotted side. Reattach the straps and lock the clamp back in place.
12. You can also easily replace the rear blade by unlatching the latch (item **4**) and removing the two rear straps (items **1** & **5**) by sliding them off the assembly. You can then flip the blade over in order to use a new edge for better wiping action.

OFF-AISLE WAND (Optional)

The SCV is equipped with a ready-to-use built-in telescoping off-aisle wand system for use in hard to reach areas. By turning the *pump switch* ON (located on the control console, see page 11 for illustration) the off-aisle wand is ready to use in seconds. The wand is also equipped with the patented flip-flop tool that allows the operator to switch from scrub brush to squeegee tool by just rotating the tool end.

OFF-AISLE WAND TOOL (Optional)

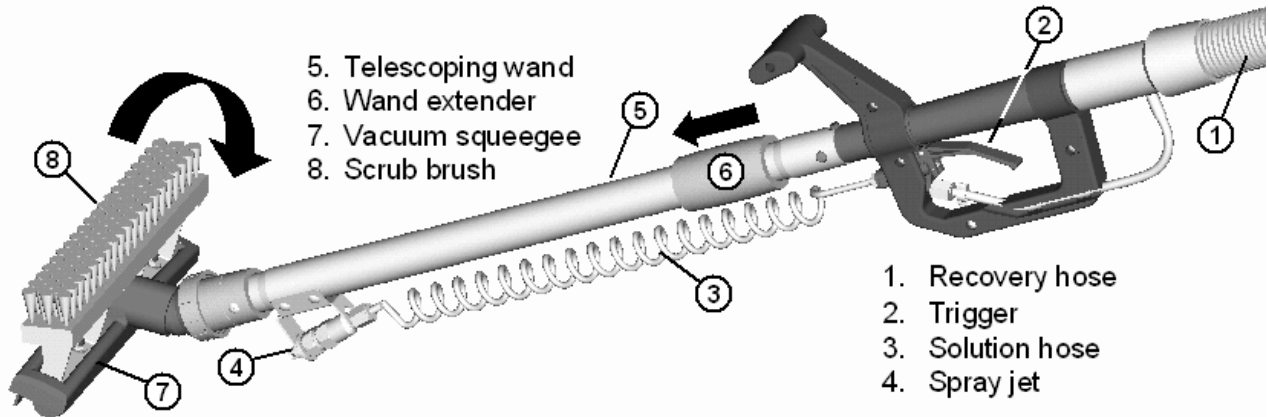

The off-aisle wand tool as described in the previous page is composed of the following items:

1. The **recovery hose** is connected to the end of the wand on one end and to the diverter assembly (item F) on the other end. This hose has swivel cuffs on both ends that allow the operator a good range of motion and the solution hose to be inside the recovery hose.
2. The **trigger** controls the solution flow to the spray jet. Squeezing the trigger opens an internal valve to dispense cleaning solution.
3. The coiled **solution hose** acts as a conduit from the trigger to the spray jet, and allows hose to be extended along with the wand.
4. The **spray jet** dispenses the cleaning solution to soak soiled areas that are not accessible to the main scrub deck.
5. The **telescoping wand** allows the length to be adjusted for operator comfort and better storage when not in use.
6. Sliding the **wand extender** forward (as shown above) extends the wand length during use and retracts the wand by pulling it back for the storage position.
7. The flip-flop tool gives the operator complete flexibility when changing from the **scrub brush** mode to **vacuum squeegee** mode by simply rotating the end.

When the off-aisle wand switch is turned ON, the off-aisle wand switch LED will be lit as well as the battery gauge will flash to indicate that you are in the off-aisle tool mode. This switch turns on the pump to supply solution to the wand spray jet and the vacuum motor to recovery the dirty water. When the recovery tank is full, the vacuum motor and the solution pump automatically shuts off.

THE SCV RIDER

This machine was designed with total operator comfort and ease of use in mind. All machine components have been designed as a total system to efficiently clean dirty floors. The SCV has four available scrub head types and sizes to fit specific applications. *Please contact your Minuteman representative for specific recommendations for the correct scrub head type, size, and brush type and chemical applications.*

Before using the machine, always perform the following steps to ensure proper machine operation.

- Check under the machine for leaks.
- Check the rear and side squeegees for wear and damage.
- Check the steering for proper operation.
- Check the solution and recovery tanks.

After using the machine, always perform the following steps:

- Check the battery charge level. Charge batteries if necessary. When charging batteries, extra precaution is required:
 - Battery acid can cause burns. When working on or around batteries, always wear protective clothing and safety glasses. Remove metal jewelry. Do not lay tools or metal objects on top of the batteries.
 - Charging batteries generate explosive gasses. **DO NOT CHARGE BATTERIES WHEN OPEN FLAMES OR SPARKS ARE PRESENT. DO NOT SMOKE.** Make sure the charger is turned off before disconnecting it from the batteries. Charge the batteries in a well-ventilated area. Fluid levels should be checked before and after charging and maintained at the proper levels. If low, add water until the metal plates are covered. If the machine is not used for an extended period of time, batteries should be kept fully charged with a boost charge once a week.
- Check for wire, string, or twine wrapped around the scrub brushes.
- Check the squeegees for wear and damage.
- Check the rear squeegee suction hose and off-aisle wand hose for obstructions.
- Empty and clean the debris box (cylindrical systems only).
- Drain and clean the recovery tank.
- Check under the machine for leaks.
- Check the service records to determine maintenance requirements.

WARNING!

- **Be sure you understand the machine controls and their functions.**
- **While on ramps or inclines, avoid sudden stops when tanks are filled.**
- **Avoid abrupt sharp turns. Slow down driving speed when going downhill.**
- **Always drive up when cleaning ramps.**

MACHINE OPERATION

Follow the instructions in preparing the machine for use as described in this manual.

1. While seated on the machine, adjust the steering wheel to desired position using the tilt lever.
2. Turn the **Key switch ON (I)**. The Battery Gauge will light up and display the *Remaining Battery Life*.

3. Select one of the five available **Modes** on the **Control Console** for the required task. Refer to the *Main Keyboard section* of this manual for a complete description of the functions.
4. Determine the direction you need to travel by selecting **forward** or **reverse** on the **Directional Switch**. Vary the pressure exerted on the accelerator pedal to propel the machine at the desired speed.
5. Stepping on the **Accelerator Pedal** turns on the *Transport, Brushes, Water Flow, Vacuum* and lowers the *Rear Squeegee* accordingly to the Mode selected. If the operator steps on the accelerator pedal before, or turns the key switch “ON” at the same time, the machine will not move as a safety precaution. Simply remove your foot off the pedal and step on the pedal again to drive the machine. Please refer to the *Main Keyboard section* of this manual for a complete description of the functions.
6. When **Reverse** is selected on the Directional Switch, the **Back-up Alarm** will be activated and the **Rear Squeegee** automatically is raised when you step on the accelerator pedal. However, the Scrub brushes will continue to rotate and solution will continue to flow.
7. Start scrubbing by driving the machine forward in a straight line at 3/4 speed and overlap each path by 2 to 3 inches. Adjust your speed; brush pressure and solution flow according to the condition of the floor.

CAUTION!

To avoid any damage to the floor, keep the machine moving when the brushes are turned on.

10. When scrubbing, check behind the machine occasionally to see that all the dirty water is being picked up. If streaking occurs, your **Recovery Tank** may be *full*, the **Squeegee hose** may be *clogged*, or the **Rear Squeegee** may require some *adjustment*.
11. Make the necessary adjustments on the **Rear and Side Squeegees** if streaking occurs both in straight paths and in turns. Please refer to the *Rear Squeegee* and *Side Squeegee* section of this manual before making any adjustments.
12. In cases where the floors are extremely soiled and dirty, the **Double Scrub** mode may be needed. As described in the *Main Keyboard section* of this manual, this mode allows the operator to be able to scrub an area without recovering the cleaning solution with the rear squeegee in the raised position (no vacuum) to allow the cleaning solution a longer time to loosen dirt. A final pass on the same area is made with the mode switched over to either **Full Function** or **Vacuum Only** mode to recover the dirty water.
13. The recovery tank has a safeguard for overflow protection to guard against water from entering the vacuum system when the recovery tank is full. The vacuum will stay ON for 15 seconds and then shut-off automatically. A ball float shut-off system has also been integrated into the Recovery Tank. When the dirty water reaches a certain level, the ball gets suctioned into the vacuum manifold and blocks the airflow thus, preventing the machine from picking up more liquid. When this happens, the operator is then required to stop scrubbing and empty the recovery tank.
14. To stop scrubbing, select the **Transport mode**. This will automatically stop the **Solution Flow**, raise the **Scrub deck**, and raise the **Rear squeegee** (there is a 15 second delay for the vacuum motor).
15. Drive the SCV to a designated dirty water disposal area and empty the Recovery tank. To empty, remove the **Drain hose** from its storage hanger. Unscrew the plug and hold the hose end above the water level in the tank to avoid sudden, uncontrolled flow of dirty water.

With the plug completely off, carefully direct the water flow to the desired drain. Reinsert the plug and tighten and return to its storage hanger.

16. The recovery tank should be rinsed out to remove solids in the tank. Open the **Cleanout cap** to remove the **Stopper plug**. Tilt the recovery tank (similar to accessing the batteries) and clean the sludge that has settled in the sump area by either back flushing or by scraping it out. Be sure to tightly secure the **Stopper plug** and cleanout cap before continuing to operate the scrubber.
17. Refill the solution tank and continue scrubbing until the job is done or when the machine runs out of power.
18. The **battery gauge bar icon** will flash to signal the operator that the machine is almost out of power. Once this signal is displayed to the operator, *all functions will shut off* (brush will turn off and the scrub deck will raise up, water flow will cease, the rear squeegee will raise up and the vacuum motor will turn off) including the transport mode. The operator has to turn the **key switch OFF and then, ON to reset** the machine. The machine then will only have a few minutes left of reserve power for a short *Vacuum only mode* to pick up remaining solution on the floor and *Transport* power to drive to the battery recharging station.

AFTER USE:

1. When finished scrubbing, select the **Transport mode**, *all functions will shut off* (brush will turn off and the scrub deck will raise up, water flow will cease, the rear squeegee will raise up and the vacuum motor will turn off). Drive the machine to a service area for daily maintenance and review items that may need service.
2. Empty the solution tank, by directly opening the **Garden hose valve** underneath the machine into a drain on the floor or use a garden hose and attach it to the fitting to remotely drain the solution tank. Rinse the tank with clean water to prevent any build-up of dried up chemicals that could cause clogging in the plumbing.
3. Empty the recovery tank as described on line **15** and **16**.
4. Remove the **brushes** or pad holders and rinse them in warm water and hang to dry.
5. Remove the **rear squeegee**, rinse with warm water and reinstall after cleaning.
6. Remove the **side squeegees**, rinse with warm water and remove the **debris box** (cylindrical system only) and clean thoroughly. The debris box can be removed from either side of the machine by tilting the box up and away from the housing and then pulling it out. Reinstall the debris box and side squeegees after cleaning.
7. Check the **maintenance schedule** on the next page and perform any required maintenance before storing the machine.
8. Store the machine indoors in a clean dry place. Keep from freezing. Leave solution and recovery tank lids open for ventilation to prevent odor build-up.
9. Turn **Key switch OFF (O)** and remove key.

MAINTENANCE SCHEDULE

Daily	Weekly	Monthly	Yearly
Charge Batteries	Check Each Battery Cell(s) Water Level	Lubrication – Grease Fittings, chains, etc.	Check Carbon Brushes
Check/Clean Tanks & Hoses	Inspect Scrub Housing Skirts		
Check/Clean/Rotate the Brushes/Pads	Inspect and Clean Solution Filter		
Check/Clean the Squeegee	Check Foot/Parking Brake for Wear & Adjustment		
Check/Clean Vacuum Shut-Off Float	Clean Spray jets on Cylindrical System		
Check/Clean the Vacuum Motor Foam Filter			
Clean Hopper on Cylindrical System			

- Have Minuteman check the vacuum motor carbon motor brushes once a year or after 300 operating hours. The brush motor carbon brushes should be checked every 500 hours or once a year.

NOTE: Refer to the Service Manual for more detail on maintenance and service repairs.

LUBRICATING THE MACHINE

Regularly scheduled lubrication of certain machine parts should be performed to insure trouble-free operation of the machine. *Apply a generous amount of grease into the fittings on the machine until grease seeps out around the bearings.*

The grease points are listed below:

- Rear squeegee caster wheel axle (2)
- Rear squeegee caster wheel stem (2)
- Side squeegee caster wheel axle (2)
- Side squeegee caster wheel stem (2)
- Steering wheel chain sprockets and idlers

Apply lubricant or light machine oil to lubricate the:

- Rear squeegee general pivot points
- Side squeegee general pivot points
- Scrub deck linkages
- Drive wheel assembly seals.

GENERAL MACHINE TROUBLESHOOTING

Problem	Possible Cause	Remedy
Poor water pick-up	Worn or torn squeegee blades	Rotate or replace blades
	Squeegee out of adjustment	Adjust so blades touch floor evenly across entire width
	Recovery tank full	Empty recovery tank
	Recovery tank drain hose leak	Secure drain hose cap or replace
	Recovery tank lid gasket leak	Replace gasket lid cover properly
	Debris caught in squeegee	Clean squeegee
	Vacuum hose clogged	Remove debris and flush hose
	Using too much solution	Adjust solution control valves
	Vacuum hose to squeegee or recovery tank disconnected to squeegee or damaged	Reconnect or replace squeegee hose
Poor scrubbing performance	Worn brushes	Rotate or replace brushes
	Wrong brush or cleaning chemical	Consult Minuteman
	Debris caught on scrub brushes	Remove debris
	Moving machine too fast	Slow down
	Low battery charge	Recharge batteries
Inadequate solution flow or no solution to the floor	Solution tank empty	Fill solution tank
	Recovery tank full	Empty recovery tank
	Solution lines, valves, filter or spray jets clogged	Flush lines, and clean solution filter and spray jets.
	Solution solenoid valve	Clean or replace valve
No solution to off-aisle wand spray jet	Recovery tank full	Empty recovery tank
	Solution tank empty	Refill solution tank
Machine does not run	Emergency stop switch tripped	Activate switch by turning as indicated by arrows.
	Operator seat safety switch	Operator has to be seated. Check for open circuit and replace
	Main system controller	Check error fault codes (See service manual)
	Tripped 100 amp circuit breaker	Check for electrical short circuit Reset machine: Rest breaker and turn key switch off and restart.

No FWD/REV drive	Drive system speed controller.	Check error fault codes (See service manual) Reset machine: Turn key switch off and restart.
	Emergency stop switch tripped	Activate switch by turning as indicated by arrows.
Vacuum motor does not turn on	Recovery tank full	Empty recovery tank
	Excessive foaming in recovery tank.	Empty recovery tank. Use less or change chemical. Use defoaming agent.
	Five LEDs flashing on Battery Guage	Check for motor overload. Reset machine: Turn key switch off and restart.
Poor sweeping performance (Cylindrical System)	Debris box full	Empty and clean debris box
	Brushes worn	Replace brushes
	Bristles have taken a set	Rotate brushes
Solution tank empty indicator light on	Solution tank empty	Refill solution tank
	Faulty float switch	Replace float switch
Recovery tank full indicator light on	Recovery tank. full	Empty recovery tank.
	Float switch full of debris	Clean float switch.
	Faulty float switch	Replace float switch

SCV 24/26 FAULT / DIAGNOSTIC CODES

Diagnostic Codes

The number of flashing bars on the battery gauge represent fault codes as indicated below:

Low battery voltage <i>Check condition of battery and connections</i>	1
Traction Motor fault <i>Check all connections between the motor and control system</i>	2
Brush Motor fault <i>Check all connections between the motor and control system</i>	3
Freewheel Errors <i>Check condition of freewheel switch and connections</i>	4
Vacuum Motor fault <i>Check all connections between the motor and the control system</i>	5
Off-Aisle Wand Activated <i>Check Off-aisle wand switch position</i>	6
Throttle fault <i>May indicate incorrectly wired or faulty potentiometer</i>	7
Control system fault <i>Check all connections are secure</i>	8
Solenoid brake fault <i>May indicate open or short circuit solenoid brake</i>	9
High battery voltage <i>Check condition of battery and connections</i>	10
Throttle Displaced on start up <i>Restart keyswitch-throttle was activated prior to ignition</i>	Ripple

**Please refer to manual for detailed
trouble shooting information**

715904

EXPLODED VIEWS

MAIN ASSEMBLY I

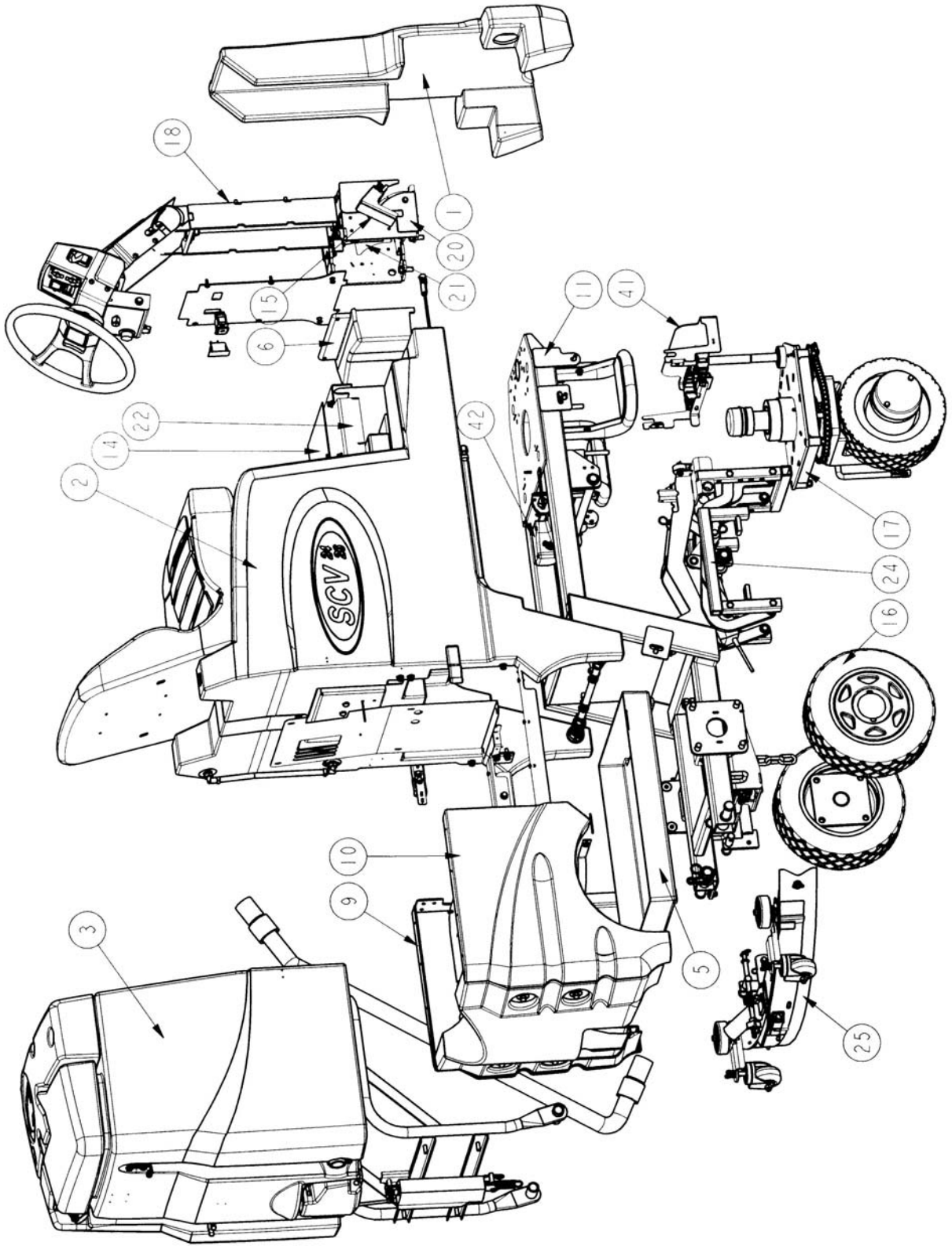

MAIN ASSEMBLY II

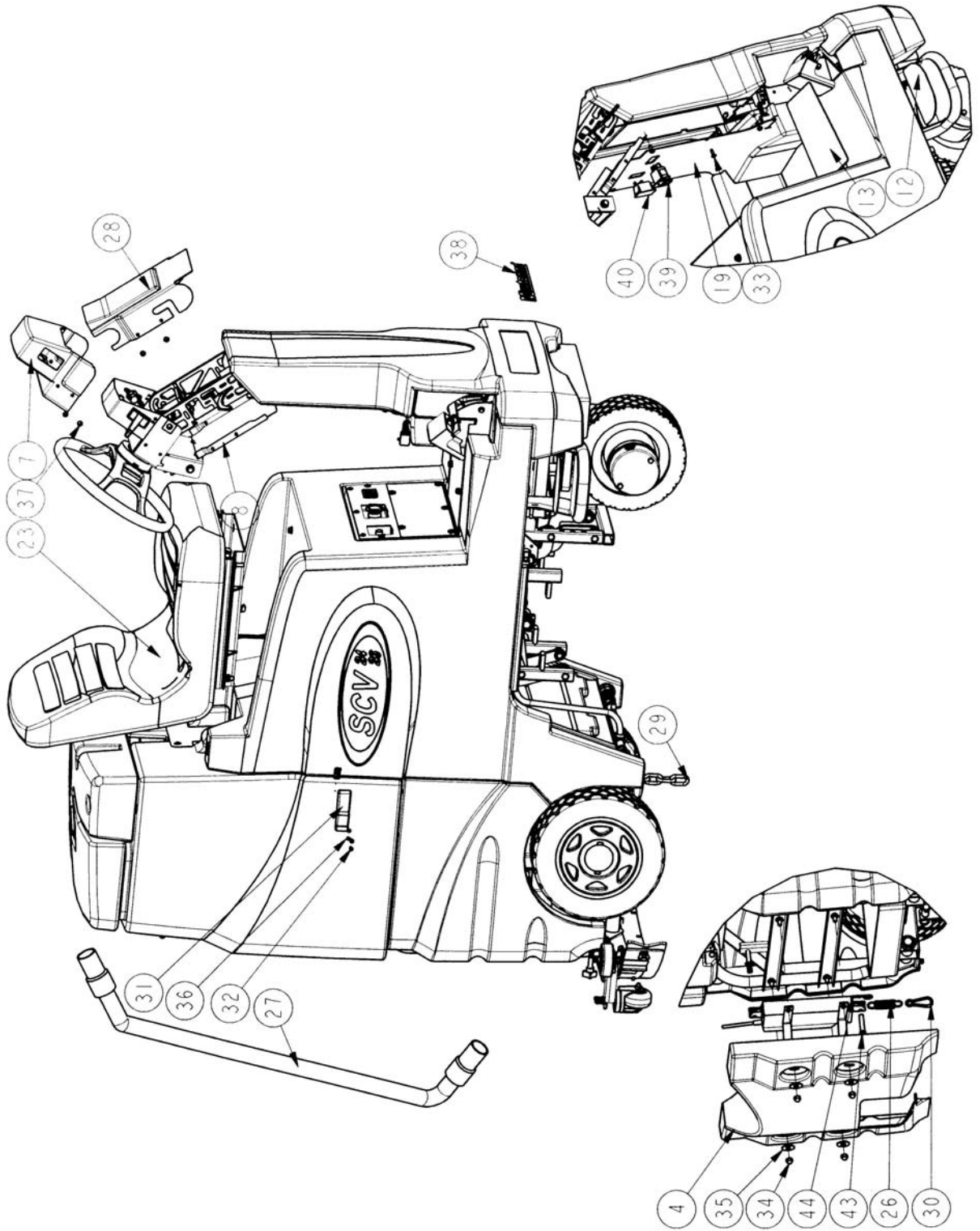

MAIN ASSEMBLY BOM (SEE MAIN ASSEMBLY I & II)

BILL OF MATERIAL - MAIN ASSEMBLY			
ITEM	PART NO.	REQ'D	DESCRIPTION
1	241001	1	BUMPER, FRONT SCV24
2	241012	1	SOLUTION TANK ASSY w/OAW, SCV 24/26
3	241013	1	RECOVERY TANK ASSEMBLY, SCV 24/26
4	241023	1	REAR BATTERY COVER, SCV 24/26
5	241024	1	BATTERY BOX, SCV24/26
6	241025	1	BOTTOM STEERING COLUMN COVER, SCV 24/26
7	241028	1	MAIN STEERING COVER, SCV 24/26
8	241030	1	STEERING COVER BOTTOM, SCV 24/26
9	241045	1	LH BATTERY PANEL ASSY, SCV 24/26
10	241046	1	RH SIDE PANEL ASSY, SCV 24/26
11	241101	1	MAIN FRAME WELDMENT, SCV 24/26
12	241117	2	FRONT FOOT STEP ANTISKID, SCV 24
13	241138	1	FOOT REST ANTISKID, SCV 24/26 RH
14	241139	1	FLOOR PANEL ANTISKID, SCV 24/26
15	241143	1	ADJUSTABLE PEDAL ANTISKID, SCV 24/26
16	241201	2	REAR WHEEL ASSY, SCV 24/26
17	241251	1	FRONT DRIVE ASSEMBLY (10"), SCV 24/26
18	241301	1	STEERING ASSEMBLY, SCV 24/26
19	241323	1	REAR STEERING COLUMN COVER, SCV 24/26
20	241324	1	RIGHT FOOT PEDAL AREA COVER, SCV 24/26
21	241325	1	LEFT FOOT PEDAL AREA COVER, SCV 24/26
22	241351	1	FLOOR PANEL WELDMENT, SCV 24/26
23	241365	1	SEAT SUB ASSEMBLY, SCV 24/26
24	241451	1	LINKAGE ASSY W/ACTUATOR, SCV 24/26
25	241701	1	SQUEEGEE MECH ASSY
26	241970	1	SPRING-EXT .75 O.D. X 3.0 F.L. CLOSED ENDS
27	281078	1	HOSE ASSY - SQUEEGEE, SCV 28/32
28	282029	1	STEERING COVER, TOP
29	320996	1	STATIC GROUNDING CHAIN
30	430103	1	SPRING HOOK 2450S
31	450207	2	LATCH, SOFT #C7-10
32	710328	10	SCR-MC 8-32 X .37 ST PL - ROUND HEAD
33	711160	6	#10 X 5/8 HI-LO
34	711353	4	NUT, ACORN 5/16-18
35	711507	4	WSR-FLAT .37 X 1.12 X .06
36	711542	10	WSR-HELICAL #8
37	712540	12	SCR-MC TR HD 10-24 X .37 SS
38	715385	1	MINUTEMAN LOGO 1.4 X 9.6
39	748202	1	SWITCH, SPST ILLUM
40	748205	1	SWITCH, BLANK KNOCKOUT
41	748208	1	CABLE ASSY, DRIVE MOTOR SCV 2426
42	748213-1	1	ACTUATOR, W/WEATHER PACK SCV SQUEEGEE
43	831965	1	3/8 x 1.63" CLEVIS PIN
44	833374	1	HAIRPIN COTTER 3/8

MAINFRAME ASSEMBLY

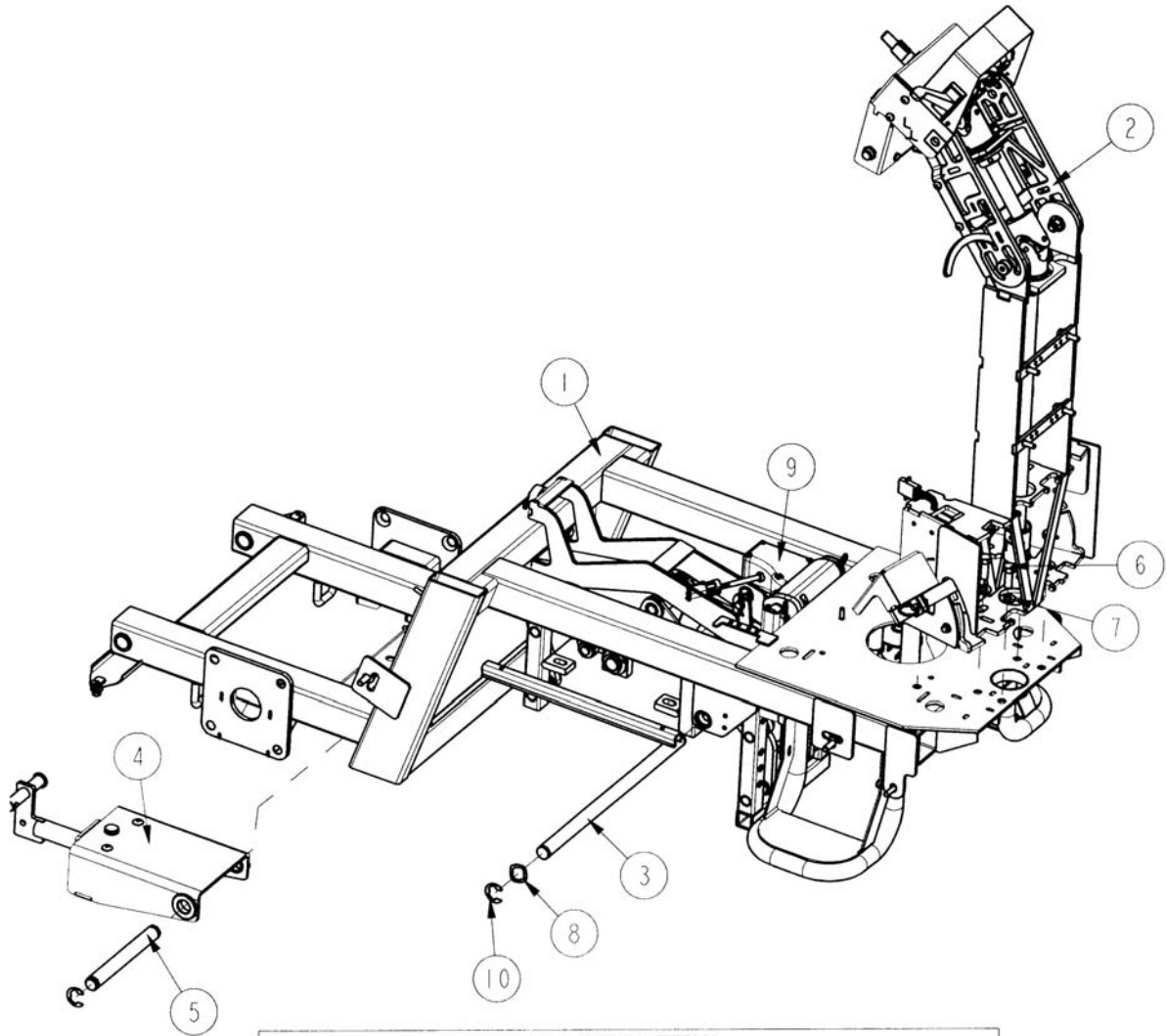

BILL OF MATERIAL			
ITEM	PART NO.	REQ'D	DESCRIPTION
1	241101	1	MAIN FRAME WELDMENT, SCV 24/26
2	241301	1	STEERING ASSEMBLY, SCV 24/26
3	241480	1	LINKAGE ATTACHMENT SHAFT, SCV 24/26
4	241710	1	SQUEEGEE LIFT MECH ASSY, SCV 24/26
5	320909	1	LIFT MECH ASSY PIVOT SHAFT
6	711242	6	BLT-HEX 3/8 -16X1.00 ZP
7	711515	8	WSR-FLAT .406 X .812 X .0625
8	711583	2	WSR-WAVE .78 X 1.00 X .02
9	748213-1	1	ACTUATOR, W/WEATHER PACK SCV SQUEEGEE
10	809148	4	RETAINING RING - "E" TYPE EXT .75

LINKAGE ASSEMBLY

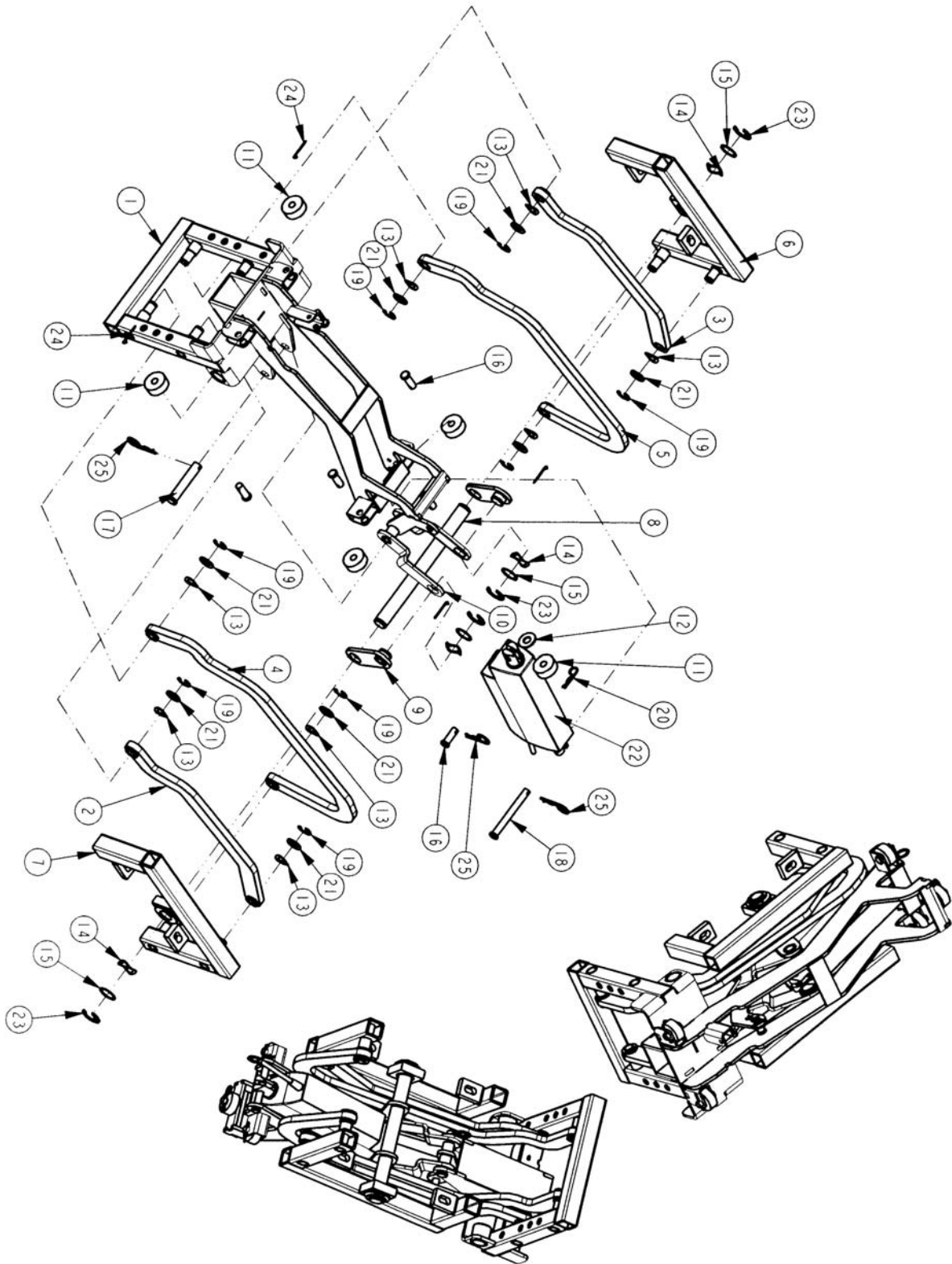

LINKAGE ASSEMBLY BOM

BILL OF MATERIAL - 241451			
ITEM	PART NO.	REQ'D	DESCRIPTION
1	241452	1	FIXED PIVOT WELDMENT, SCV 24/26
2	241462	1	LEFT UPPER LINK ASSEMBLY, SCV 24/26
3	241464	1	RIGHT UPPER LINK ASSEMBLY, SCV 24/26
4	241465	1	LEFT LOWER LINK ASSEMBLY, SCV 24/26
5	241467	1	RIGHT LOWER LINK ASSEMBLY, SCV 24/26
6	241468	1	LEFT LIFT WELDMENT W/BUSHING, SCV 24/26
7	241470	1	RIGHT LIFT WELDMENT W/BUSHING, SCV 24/26
8	241472	1	LINK ATTACHMENT SHAFT, SCV 24/26
9	241476	2	DECK LIFT LINK WELDMENT, SCV 24/26
10	241479	1	DECK LIFT CRANK WELDMENT, SCV 24/26
11	241485	5	POLYURETHANE ROLLER, SCV 24/26
12	711508	1	WSR-FLAT .44X 10X.08]
13	711524	8	WSR-WAVE .52 X .87 X .01
14	711583	4	WSR-WAVE .78 X 1.00 X .02
15	711588	4	WSR-FLAT .75X1.00X.025
16	711668	5	CLEVIS PIN, 3/8X1 11-141
17	711669	1	CLEVIS PIN .5 X 2.5
18	711681	1	PIN CLEVIS, 3/8 X 3-1/4 ZP
19	711713	8	RETAINING RING - "E" TYPE EXT .500
20	711808	1	COTTER PIN-HAIR #13
21	712310	8	WSR- FLAT .52 X .87 X .06 PL
22	740822-1	1	LINAK ACTUATOR, 100MM STROKE, 75 W/TERMINALS
23	809148	4	RETAINING RING - "E" TYPE EXT .75
24	809311	4	PIN-COTTER 7/64 DIA X 1
25	833374	3	HAIRPIN COTTER 3/8

FRONT DRIVE ASSEMBLY

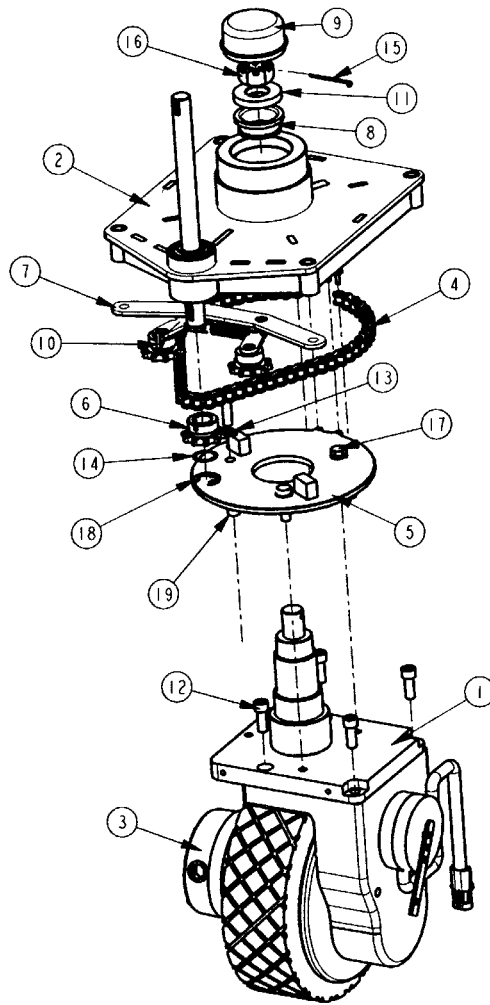

BILL OF MATERIAL			
ITEM	PART NO.	REQD	DESCRIPTION
1	241252	1	SPINDLE WELDMENT, SCV 24/26
2	241257	1	FRONT DRIVE W/ BEARING ASS'Y, SCV 24/26
3	241265	1	GEAR RESEARCH CHASSIS DRIVE 10" ASSEMBLY
4	281054	1	CHAIN, STEERING No. 40, 27.5"
5	281254	1	STEERING DISC WMT
6	281268	1	SPROCKET-RC #40, 10 TEETH, 3/4" BORE
7	281265	1	IDLER ASSY, FRONT DRIVE
8	383077	1	BEARING CONE (LM104949)
9	383250	1	GREASE CAP
10	383277	1	KEY WOODRUFF 3/16 X 3/4
11	383364	1	THRUST WASHER
12	710858	4	SCR-SC 3/8-16 X 1.00
13	711546	3	WSR-HELICAL 3/8
14	711588	1	WSR-FLAT .75X1.00X.025
15	711807	1	COTTER PIN .12 X 1.75
16	712113	1	CASTLE NUT
17	713043	3	BLT-HH 3/8-16 X 1 1/4 #5
18	809148	1	RETAINING RING - "E" TYPE EXT .75
19	809247	3	STEERING PLATE SPACER

DRIVE CABLE GUIDE ASSEMBLY

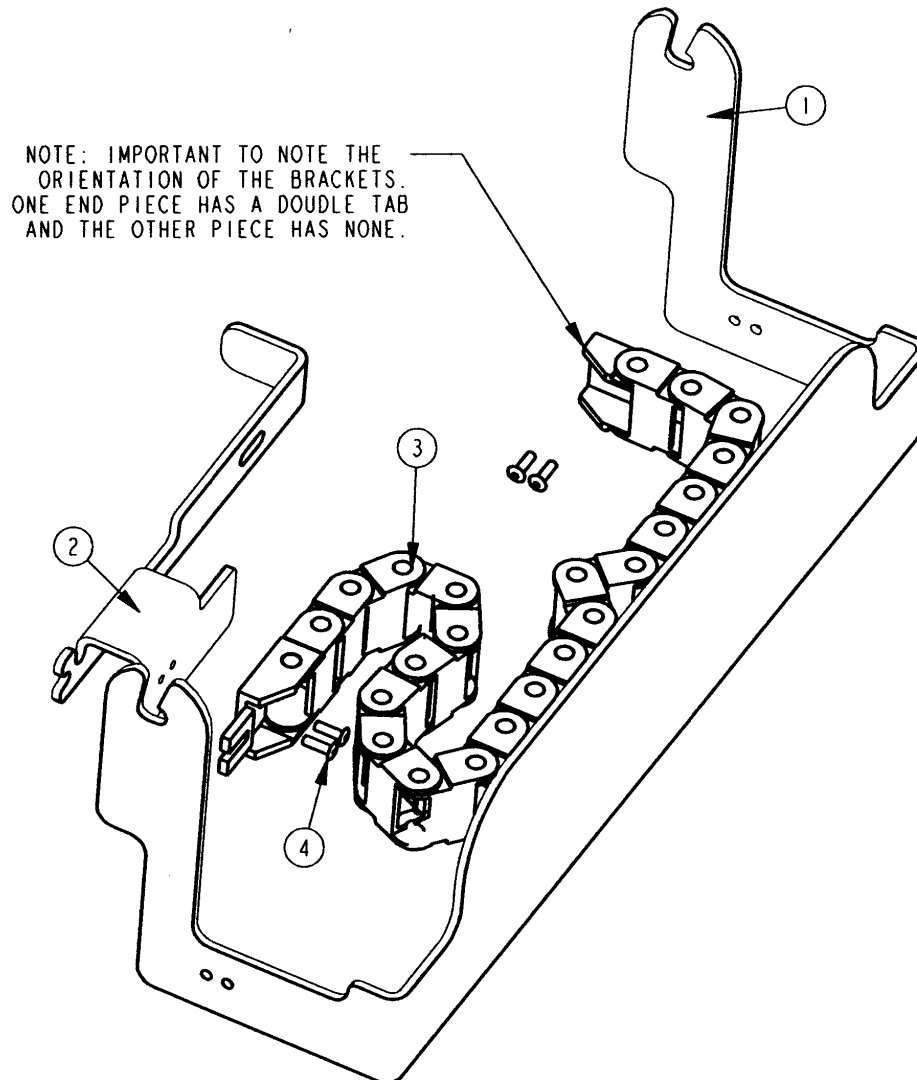

BILL OF MATERIAL			
ITEM	PART NO.	REQ'D	DESCRIPTION
1	241081	1	FIXED WIRE MTG BRKT, SCV 24/26
2	241082	1	MOVING WIRE BRACKET, SCV 24/26
3	748207	1	CABLE GUIDE, SCV 24/26
4	827666	4	POP RIVET

STEERING ASSEMBLY I

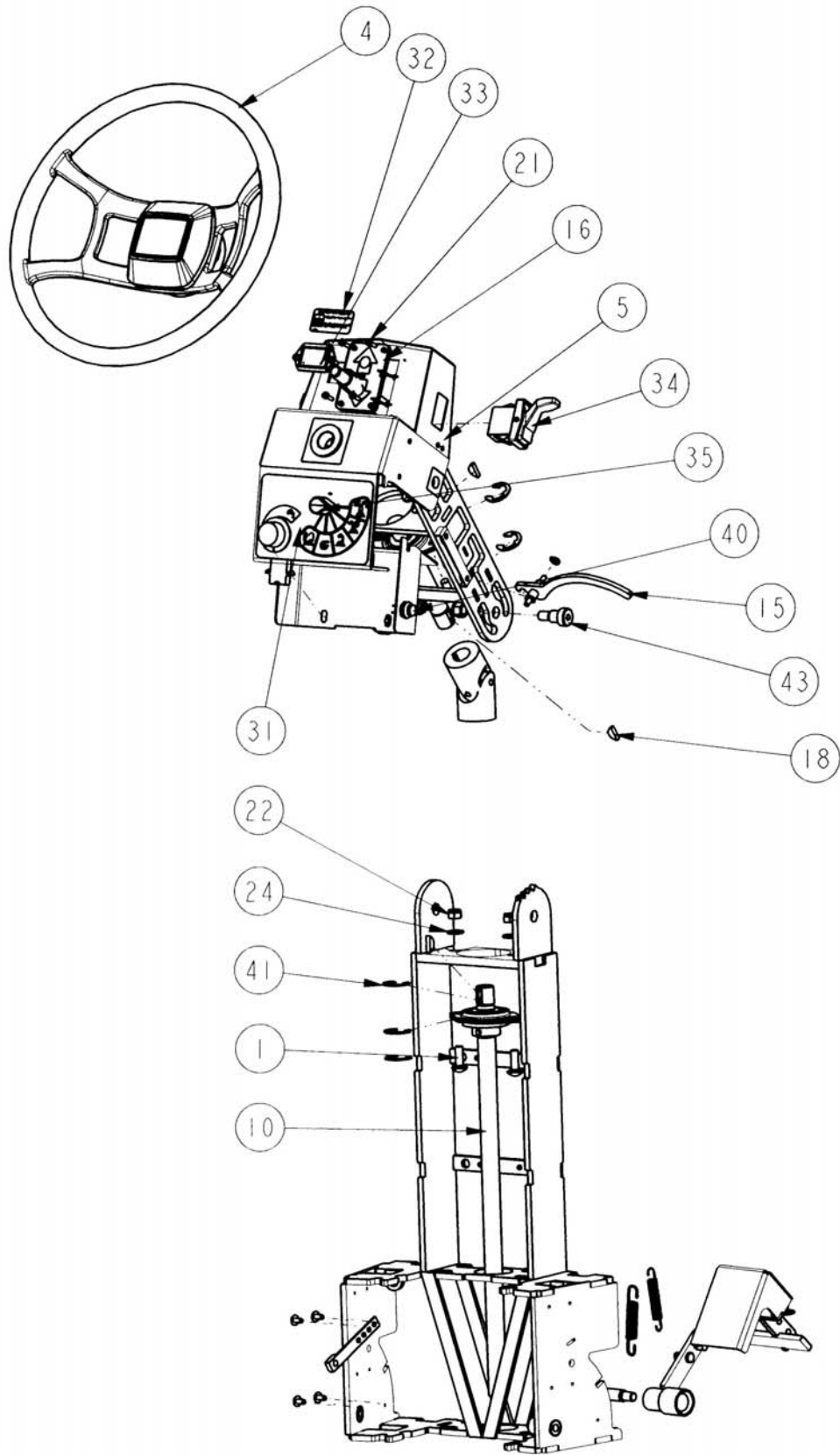

STEERING ASSEMBLY II

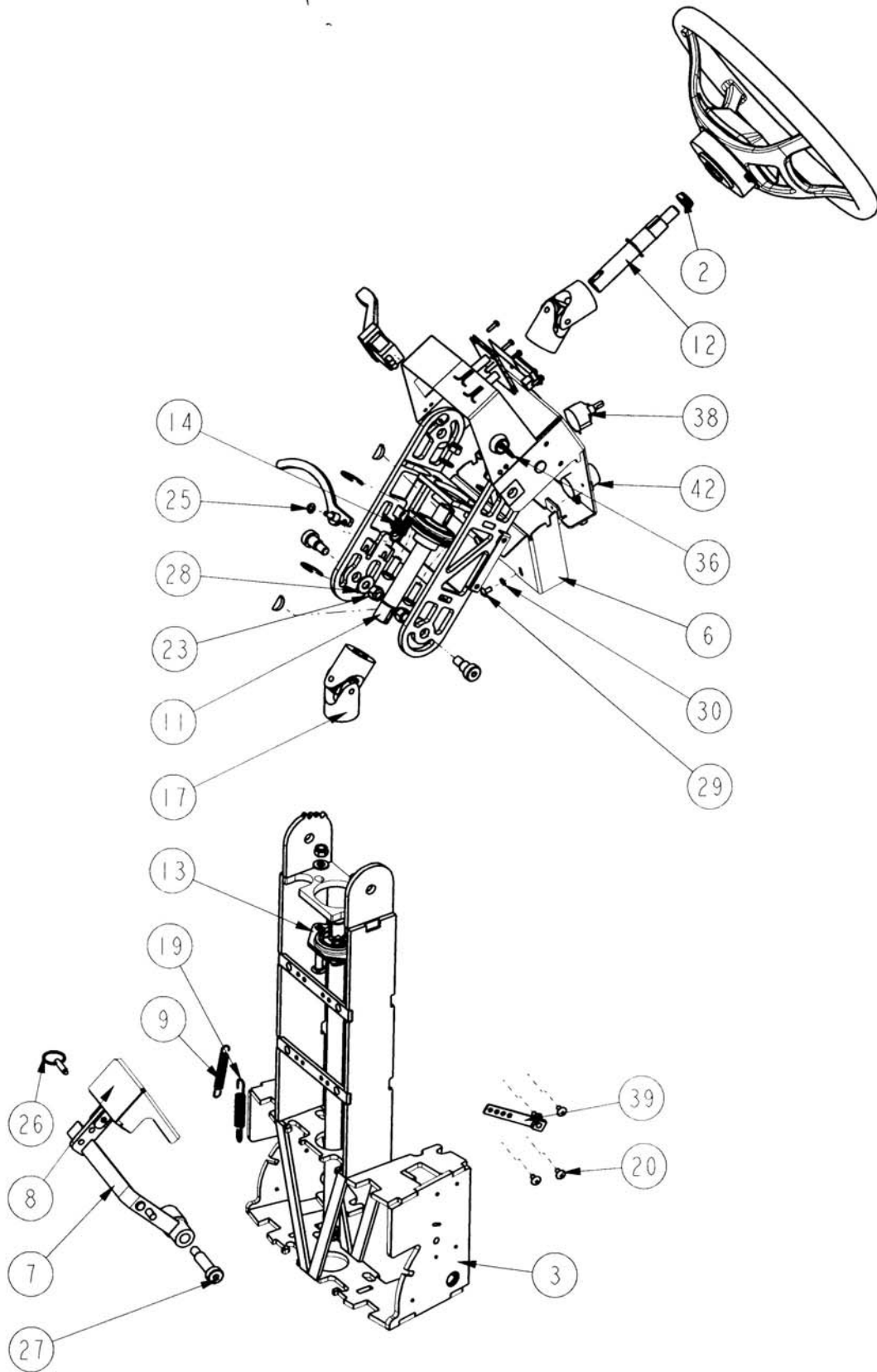

STEERING ASSEMBLY BOM (SEE STEERING ASSEMBLY I & II)

BILL OF MATERIAL			
ITEM	PART NO.	REQ'D	DESCRIPTION
1	70-516-16	4	BLT-CAR 5/16-18 X 1.00
2	368-816	1	HALF NUT NYLOC 1/2-20
3	241302	1	STEERING WELDMENT, LOWER
4	241311	1	STEERING WHEEL ASSEMBLY, SCV 24/26
5	241320	1	UPPER FIXED BRKT WELDMENT ASSEMBLY, SCV 24/26
6	241327	1	CTRL COVER PLATE ASSY, SCV 24/26
7	241331	1	ACCEL PEDAL WELDMENT, SCV 24/26
8	241336	1	PEDAL GUIDE WELDMENT, SCV 24/26
9	281047	1	SPRING, EXTENSION - 2.75"
10	281328	1	SHAFT, LOWER STEERING
11	281329	1	SHAFT, MIDDLE STEERING
12	281330	1	SHAFT, UPPER STEERING
13	281392	2	BEARING FLANGE ASSEMBLY 3/4 (MCH)
14	282303	1	SPRING - EXTENSION 1.375" F.L.
15	282309	1	ADJUSTMENT LEVER AND PIVOT PIN ASSY
16	320971	1	DIRECTIONAL INDICATOR ASSY
17	383098	2	UNIVERSAL JOINT
18	383277	5	KEY WOODRUFF 3/16 X 3/4
19	430051	1	RETURN SPRING-3.00"
20	710153	4	SCR-MC 10-32X.63 TH ZINC
21	710204	6	SCR-MC 6-32 X .50 ST PL PAN HD
22	711374	4	NUT-NYLOC 5/16-18
23	711380	2	NUT-NYLOC 3/8-16 NUT
24	711506	4	WSR-FLT .344 X .690 X .062 STL ZINC
25	711521	2	WSR-WAVE .21 X .44 X .02
26	711682	1	PIN-QUICK RELEASE, 1/4" DIA., .500 UL
27	712102	1	BLT- SHLDR 1/2 X 1-1/2
28	712301	2	WSR-FLAT .87 X .38 X .06
29	712540	2	SCR-MC TR HD 10-24 X .37 SS
30	712757	2	WSR - HELICAL #10 SS
31	715435	1	DECAL, MODE SELECTOR SCV 24/26
32	715505	1	DECAL, SOLUTION TANK INDICATOR
33	747011-1	1	BATT GAUGE ASSY TRUE CHARGE 36V
34	747015	1	SWITCH, SPDT DIRECTION ES28322
35	747020	1	KNOB-MODE SELECTOR
36	747024	1	KEYSWITCH, SPST ES2832 SOLDER
37	747025	1	POTENTIOMETER ASSY WATER FLOW
38	747027	1	SWITCH ASSY, MODE SELECTOR
39	748013-1	1	POTENTIOMETER BOX ASSEMBLY
40	748047	1	HORN SWITCH, SCV 36V
41	809148	6	RETAINING RING - "E" TYPE EXT .75
42	809874	1	KNOB, SPEED CONTROL
43	712099PLT	2	BLT- SHLDR 1/2 X 5/8

SOLUTION TANK ASSEMBLY I

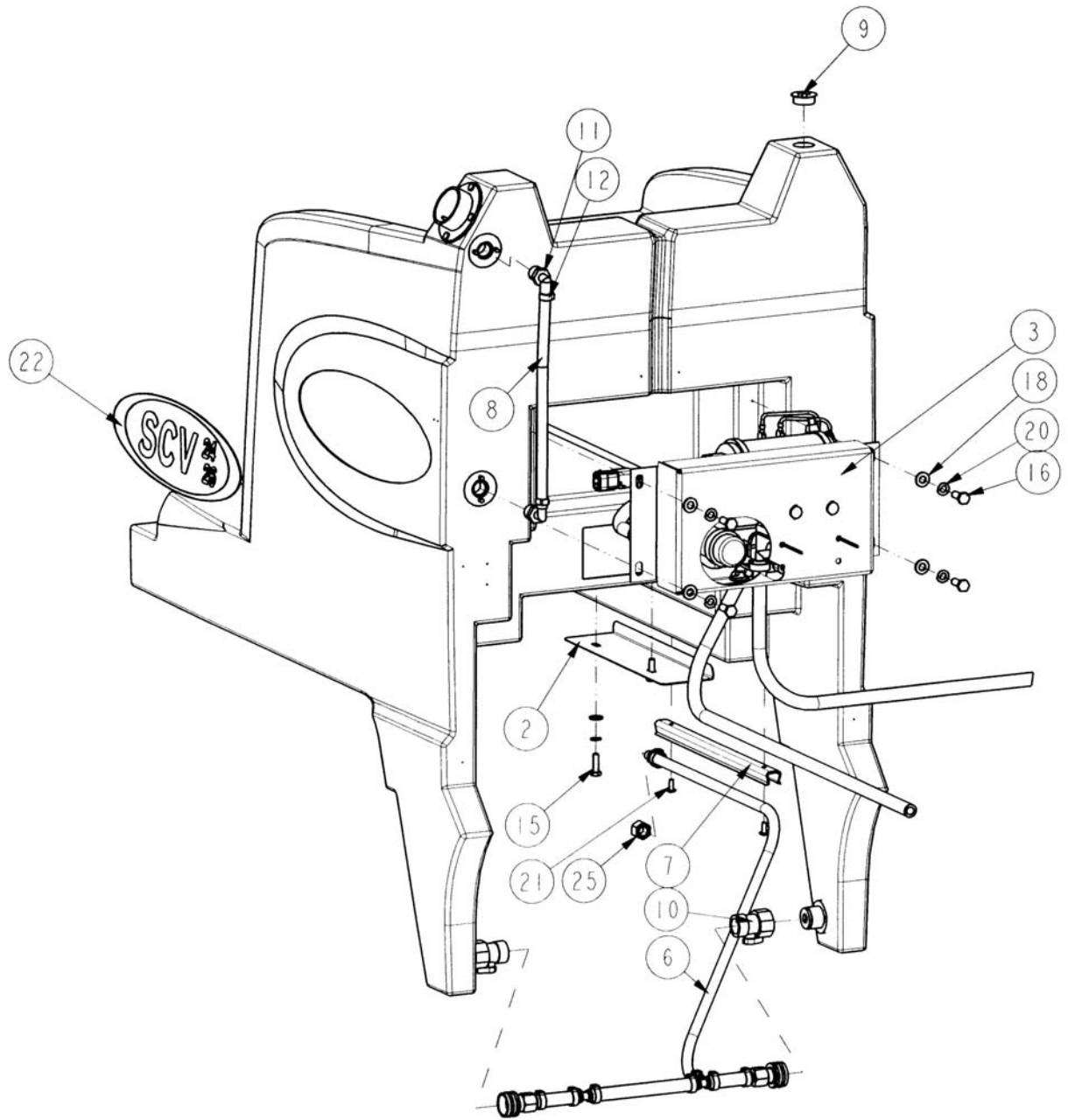

SOLUTION TANK ASSEMBLY II

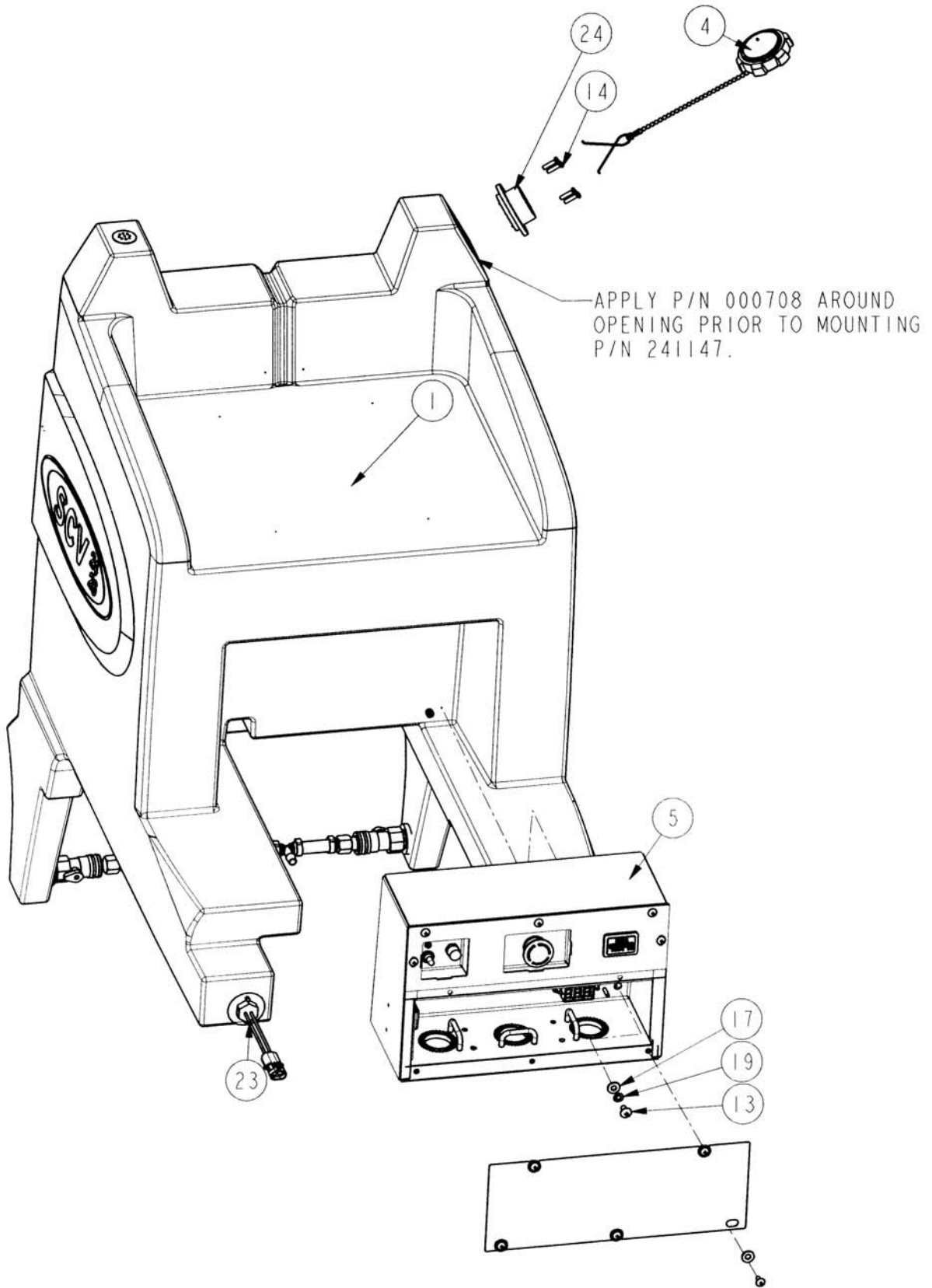

SOLUTION TANK ASSEMBLY BOM (SEE SOL. TANK ASSY I & II)

BILL OF MATERIAL			
ITEM	PART NO.	REQ'D	DESCRIPTION
1	241002	1	SOLUTION TANK, SCV24, ASSEMBLY, SPINWELDS
2	241041	1	SCV 24, WIRE BUNDLE, COVER PLATE
3	241098	1	PUMP SUB-ASSEMBLY w/OAW, SCV 24/26
4	241146	1	UNVENTED PLASTIC CAP w/LANYARD, SCV 24/26
5	241401	1	MAIN ELECT BOX ASSY, SCV 24/26
6	241722	1	SOLUTION TANK HOSE ASSY, SCV 24/26
7	260149	1	U CHANNEL 12"
8	260340	1	SOLUTION TANK SIGHT LEVEL TUBE, SCV 24/26
9	281371	1	VENT PLUG
10	281427	2	#35 SHUTOFF, BLACK, ZERO PRS
11	450040	2	FITTING 90 3/8 MPT X 3/8 BARB
12	450092	2	CRIMP CLAMP 27/64" TO 17/32"
13	710178	4	SCR-MC 1/4-20 X .50 TRUSS STPL
14	711161	4	SCR-HI/LO 10 X 3/4 STL BLK ZINC
15	711206	2	BLT-HH 1/4-20 X .87 ST PL
16	711229	4	BLT-HH 5/16 -18 - .875
17	711505	6	WSR-FLAT 1/4
18	711506	4	WSR-FLT .344 X .690 X .062 STL ZINC
19	711544	6	WSR-HELICAL 1/4
20	711545	4	WSR-HELICAL 5/16
21	712822	2	SCR-MC TR HD 10-24 X .50 SS
22	715363	2	DECAL, SCV 24/26
23	742708-4	1	FLOAT SWITCH W/WEATHER PACK
24	713508MCH	1	SPINWELD # 20D MACHINED
25	430114	1	1/4" FPT PLASTIC CAP

SEAT ASSEMBLY

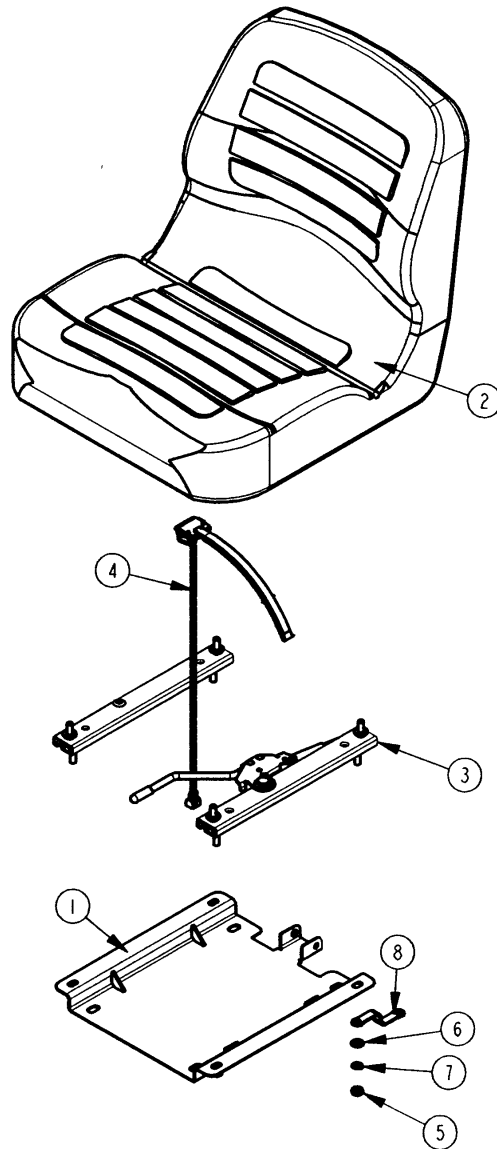

BILL OF MATERIAL			
ITEM	PART NO.	REQ'D	DESCRIPTION
1	241376	1	SEAT BRACKET WMT, SCV 24/26
2	281085	1	ASS'Y SEAT, SUPER SUBURBAN
3	281086	1	SLIDE ASS'Y KIT
4	281087-2	1	SEAT SWITCH ASSEMBLY, SCV 24/26
5	711319	4	5/16-18 HEX NUT
6	711506	4	WSR-FLT .344 X .690 X .082 STL ZINC
7	711545	4	WSR-HELICAL 5/16
8	748255	1	SEAT GROUND STRAP, SCV 24/26

ELECTRICAL PANEL ASSEMBLY

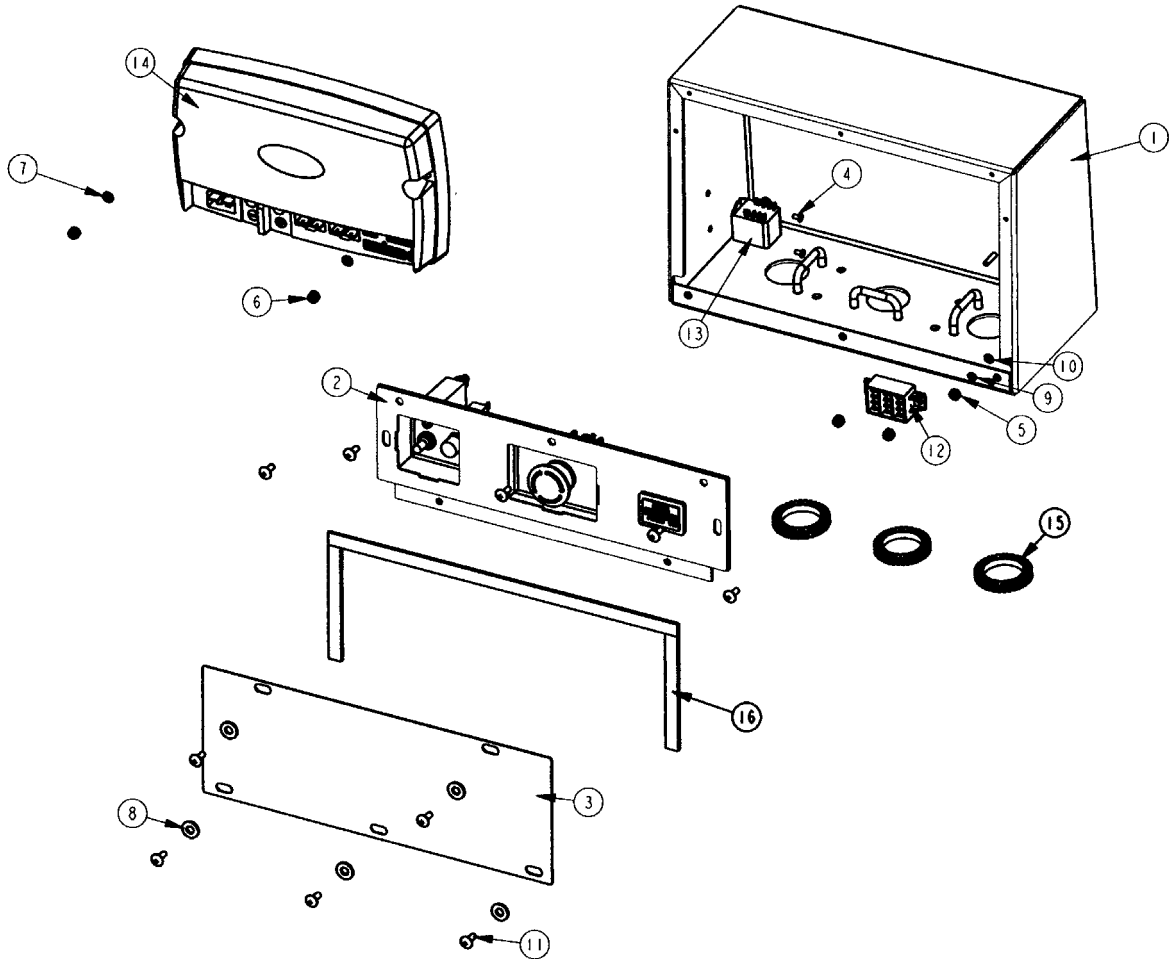

BILL OF MATERIAL			
ITEM	PART NO.	REQ'D	DESCRIPTION
1	241402	1	ELECTRICAL BOX WDMNT, SCV 24/26
2	241404	1	E-STOP PANEL ASSEMBLY, SCV 24/26
3	241409	1	ELECTRICAL PANEL DOOR, SCV 24/26
4	710202	2	SCR-MC 6-32 X .25 ST PL PAN HD
5	711304	1	NUT-HEX 8-32 ST PL
6	711372	4	NUT-NYLOC 8-32 STL ZINC
7	711502	2	WSR-FLT .170 x .38 x .032 STL ZINC
8	711505	5	WSR-FLAT 1/4
9	711542	1	WSR-HELICAL #8
10	711552	1	WSR - INTERNAL LOCK #8
11	712822	10	SCR-MC 10-24 X .50 TH SS
12	743032	1	TERMINAL BLOCK EAGLE 3
13	748204	1	RELAY, 36VDC DPDT
14	748206	1	CONTROLLER,TRIO PLUS SCV2426
15	281449	1.125	SERRATED GROMMET STRIP
16	830557	2.10	DORTITE 1/2" RM IF

RECOVERY TANK ASSEMBLY I

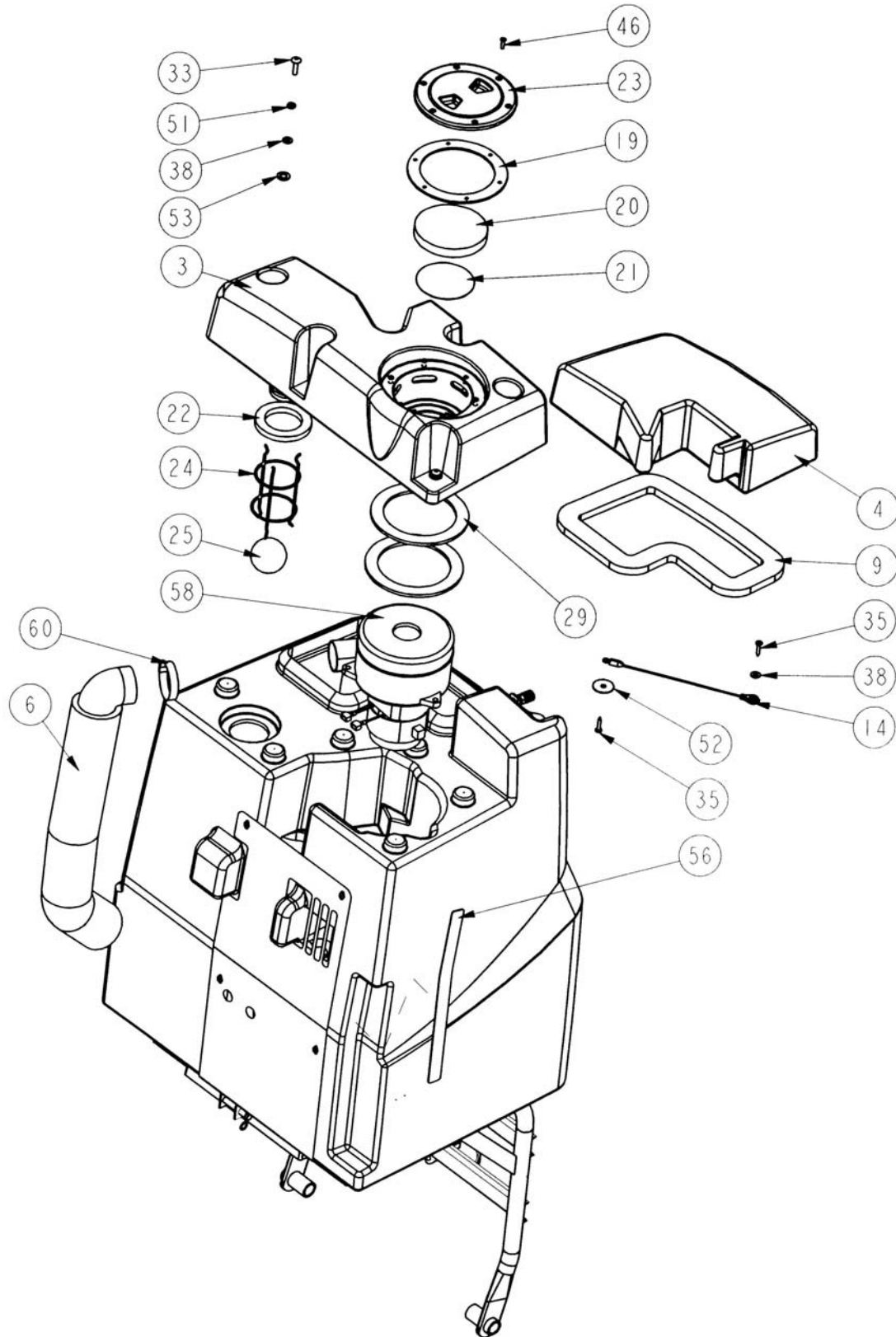

RECOVERY TANK ASSEMBLY II

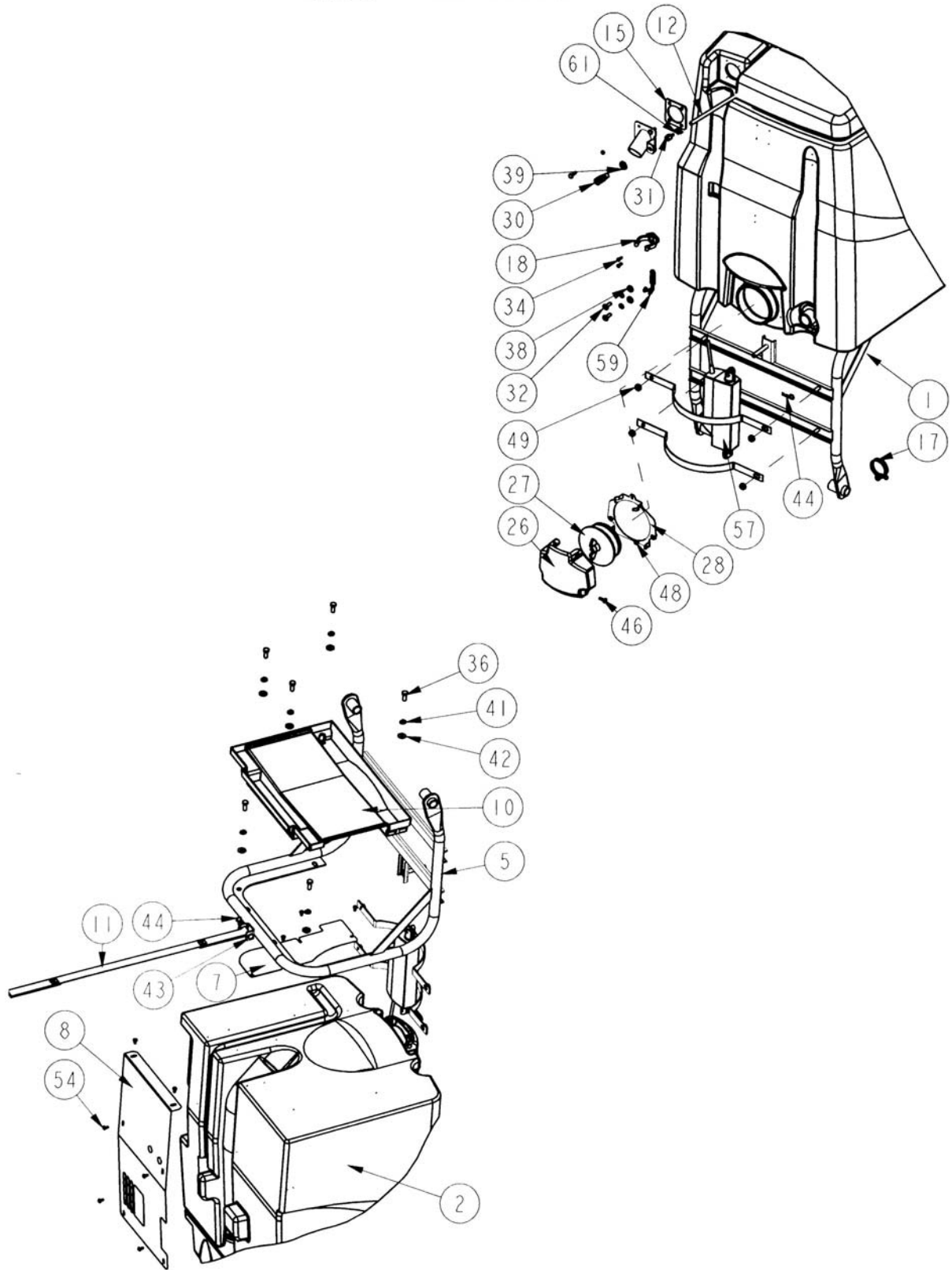

RECOVERY TANK BOM (SEE REC TANK ASSEMBLY I & II)

BILL OF MATERIAL			
ITEM	PART NO.	RECD	DESCRIPTION
34	710530	2	SCR-MC FL HD 8-32 X .50 BR5
35	711107	2	SCR-ST-A #10 X 1.00 PL
36	711228	6	BLT-HH 5/16-18 X .75 ST PL
37	711420	4	NUT- HEX JAM 5/16-18 ST PL
38	711504	7	WSR-FLAT 1/4 ID SS
39	711505	2	WSR-FLAT 1/4
40	711515	1	WSR-FLAT .406 X .812 X .0625
41	711544	2	WSR-HELICAL 1/4
42	711545	6	WSR-HELICAL 5/16
43	711575	6	WSR-FLT .31x.75x.06ST
44	711678	1	CLEVIS PIN 3/8 X 2-1/4
45	711808	2	COTTER PIN-HAIR #13
46	712516	6	SCR-BHCS #8-32 x .62 SS
47	712536	2	SCR-MC 10-24 X .62 TH SS
48	712537	4	10-24 X .75 SS TRUSS HD SCR
49	712638	2	NUT, HEX 10-24 SS NYLOC
50	712757	4	WSR - HELICAL #10 SS
51	712758	6	WSR-HELICAL 1/4 SS
52	712761	1	WSR-FLAT .28 X 1.25 X .059SS
53	712767	6	FLAT WASHER .406 ID X .75 OD X .
54	712810	9	SCR-MC 10-24 X .37 ST PL
55	712822	3	SCR-MC TR HD 10-24 X .50 SS
56	715717	1	DECAL, OVERFILL SIGHT GAUGE, SCV 24/26
57	740821-1	1	ACTUATOR ASSEMBLY, LINAK
58	742773	1	VACUUM ASSEMBLY, SCV
59	760286	1	HOOK, WIRE FORMED
60	760859	1	CLAMP, HOSE
61	830082	2	HOSE CLAMP 3/8

BILL OF MATERIAL			
ITEM	PART NO.	RECD	DESCRIPTION
1	200289	1	DUMP HOSE ASM
2	241003	1	RECOVERY TANK, SCV 24/26
3	241006	1	FIXED LID, SCV 24/26
4	241007	1	LID, RECOVERY TANK REMOVABLE
5	241037	1	RECOVERY TANK FRAME WELDMENT, SCV 24/26
6	241049	1	VAC MOTOR MUFFLER, SCV 24/26
7	241076	1	VAC WIRE COVER, SCV 24/26
8	241099	1	EXHAUST/VAC WIRE COVER, SCV 24/26
9	241193	1	REMOVABLE LID GASKET, SCV 24/26
10	241420	1	EXHAUST DIVERTER, SCV 24/26
11	241433	1	RECOVERY TANK SAFETY STRAP, SCV 24/26
12	241435	1	REC. TANK OAW SOLUTION FEED HOSE, SCV 24/26
13	241519	2	ACTUATOR PROTECT BKT
14	241704	1	REMOVABLE COVER LANYARD ASSY, SCV 24/26
15	241803	1	INLET WELDMENT GASKET, SCV 24/26
16	241805	1	REC TANK VAC INLET PIPE WELDMENT (OAW), SCV 24/26
17	260203	1	WIRE GRIP HOSE CLAMP
18	260579	1	TOOL CLIP, 1.5" HOSE
19	281018	1	GASKET, NEO 6.00 X 4.50 X .125
20	281055	1	VAC MOTOR FILTER
21	281056	1	VAC MOTOR INLET SCREEN
22	281073	1	INLET GASKET
23	281423	1	FILL CAP W/CHAIN ASSY 4.00
24	281440	1	FLOAT CAGE, SCV
25	281442	1	FLOAT BALL, SCV
26	320835	1	E52832 DUMP CAP COVER
27	320838	1	STOPPER PLUG ASM - 4"
28	320839	1	DUMP COVER SUPPORT RING
29	380035	2	MOTOR GASKET
30	450221	2	O.C. COUPLING (FEMALE)
31	450223	2	FITTING BRASS 1/8 FPT - 1/8 BARB
32	710180	2	SCR-MC TR HD 1/4-20x.75 STL ZINC
33	710189	6	SCR-MC 1/4-20 X 1.00 TRUSS PL SS

PUMP ASSEMBLY BOM

BILL OF MATERIAL			
ITEM	PART NO.	REQ'D	DESCRIPTION
1	210409	1	FITTING ADAPTOR 3/8MPTx38/FPT BR
2	241097	2	HOSE 3/8 x 31 WIRE REINFORCED, SCV 24/26
3	241430	1	OAW SOLUTION FEED HOSE, SCV 24/26
4	281089	1	FILTER, IN-LINE
5	281090	1	FITTING BRASS 3/8" FPT TEE
6	281091	1	FITTING 3/8MPTx1/8 FPT REDUCER
7	281368	1	PUMP MOUNT PLATE
8	281369	1	PUMP SUPPORT PLATE
9	281388	1	PUMP MTG PLATE
10	320254	2	HOSE 3/8 x 9.00" WIRE REINFORCED
11	342430	1	FITTING BRASS 3/8BARB 3/8 HOSE
12	342435	1	FITTING 1/4MPTx3/8HB BRASS
13	383327	4	ELBOW 1/2 MPT X 3/8 BARB
14	383332	1	FITTING BRASS 3/8 NIPPLE
15	450040	1	FITTING 90 3/8 MPT X 3/8 BARB
16	450076	4	CRIMP CLAMP SS 185R
17	450221	1	O.C. COUPLING (FEMALE)
18	450279	2	O.C. COUPLING NIPPLE (MALE X 1/8 BARB)
19	711503	8	WSR, FLAT#10
20	711504	4	WSR-FLAT 1/4 ID SS
21	711553	4	WSR- INTERNAL LOCK #10
22	712531	4	SCR-MC 10-24 X 1.00 SS
23	712565	4	SCR-MC 1/4-20X.63 SS TR HD
24	712638	4	NUT, HEX 10-24 SS NYLOC
25	712758	4	WSR-HELICAL 1/4 SS
26	742709-2	1	PUMP ASSEMBLY-SCV
27	742718-1	1	SOLENOID VALVE 36V
28	828062	2	CABLE TIE .05 x .14 x 8"
29	828368	1	MALE COUPLER
30	829129	3	HOSE CLAMP MICRO-SEAL
31	830062	1	FITTING 90 STREET ELBOW 3/8x3/8
32	830082	2	HOSE CLAMP 3/8

REAR AXLE ASSEMBLY

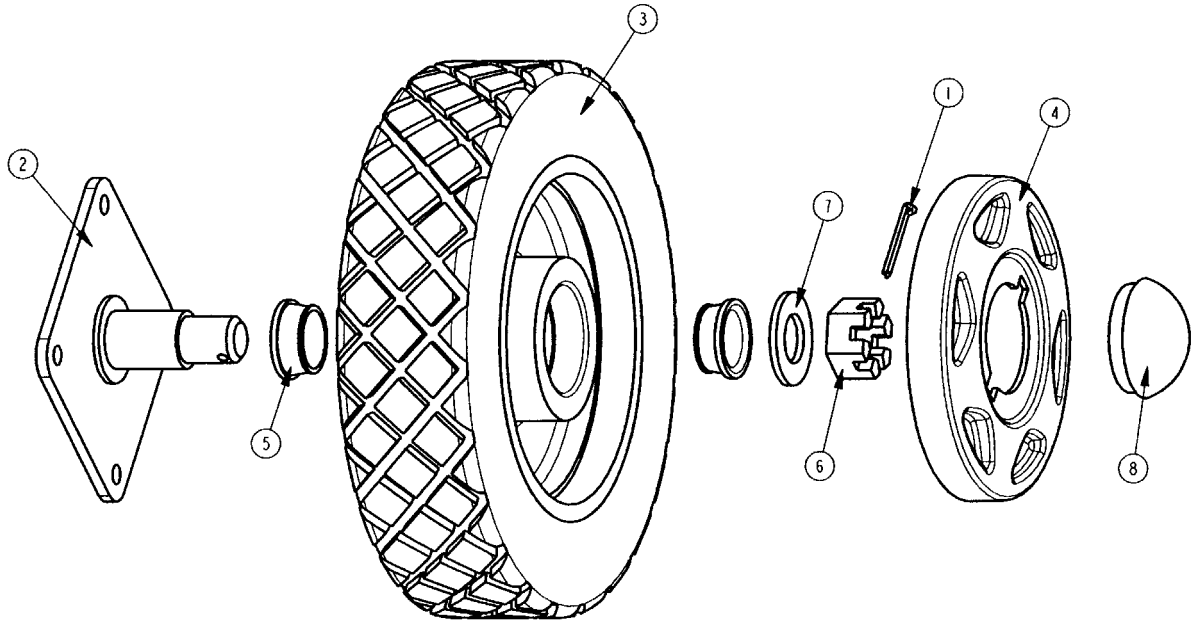

BILL OF MATERIAL			
ITEM	PART NO.	REQ'D	DESCRIPTION
1	380-632-20	1	3/16 COTTER PIN
2	241202	1	REAR AXLE WELDMENT, SCV 24/26
3	241210	1	REAR WHEEL ASSY
4	241212	1	REAR WHEEL HUB CAP, SCV 24/26
5	383194	2	BEARING CONE
6	711450	1	NUT-SLOTTED, 1-14 UNS
7	711514	1	WSR-FT 1.0 ID X 2.0 OD
8	383241PTD	1	GREASE CAP WHEEL-PAINTED

SQUEEGEE MECHANISM ASSEMBLY

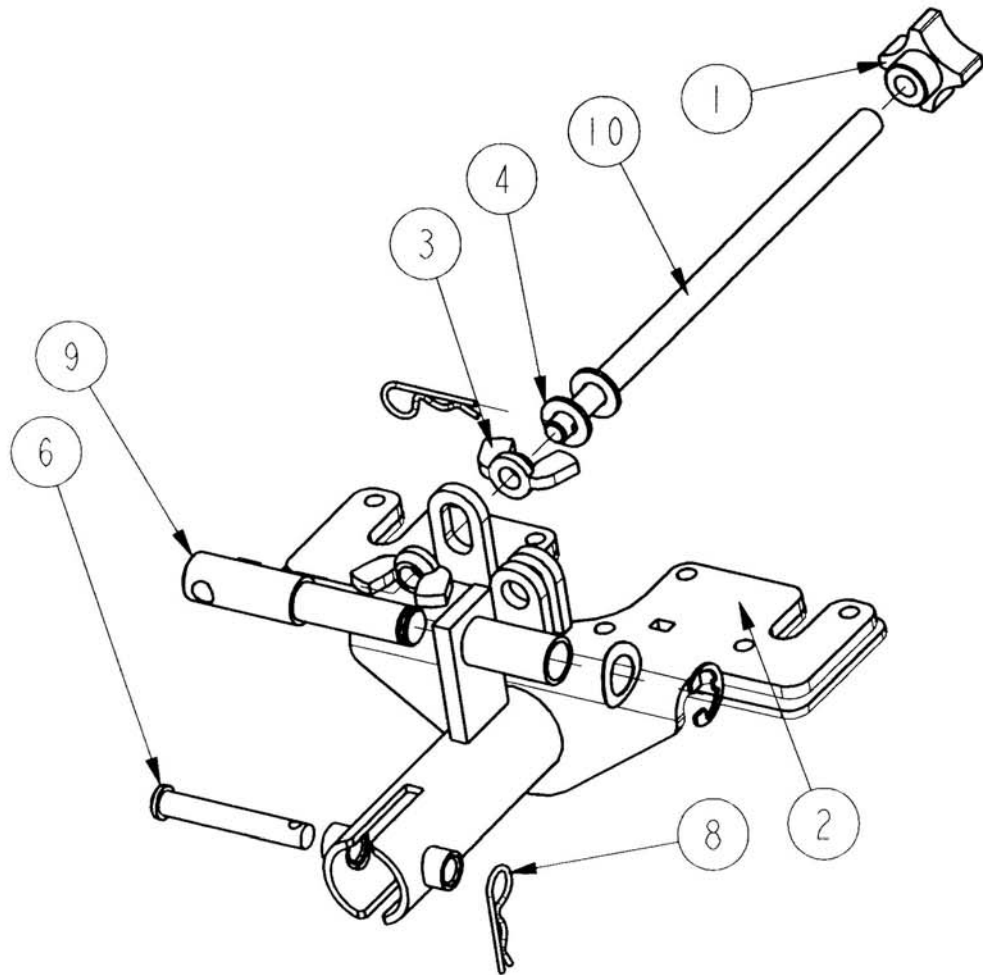

BILL OF MATERIAL - 241730			
ITEM	PART NO.	REQ'D	DESCRIPTION
1	241004	1	KNOB, 3/8-16 FOUR PRONG.
2	241751	1	REAR SQUEEGEE MOUNT PLATE WMT, SCV 24/26
3	711367	2	NUT- WING 3/8-16 ST PL
4	711506	2	WSR-FLT .344 X .690 X .062 STL ZINC
5	711524	1	WSR-WAVE .52 X .87 X .01
6	711671	1	CLEVIS PIN .31X2.13 11-10
7	711713	1	RETAINING RING - "E" TYPE EXT .500
8	711808	2	COTTER PIN-HAIR #13
9	762005	1	ADJUSTING PIN, THREADED
10	762006	1	THREADED ROD, 3/8-16 X 7.5" LG

REAR SQUEEGEE ASSEMBLY

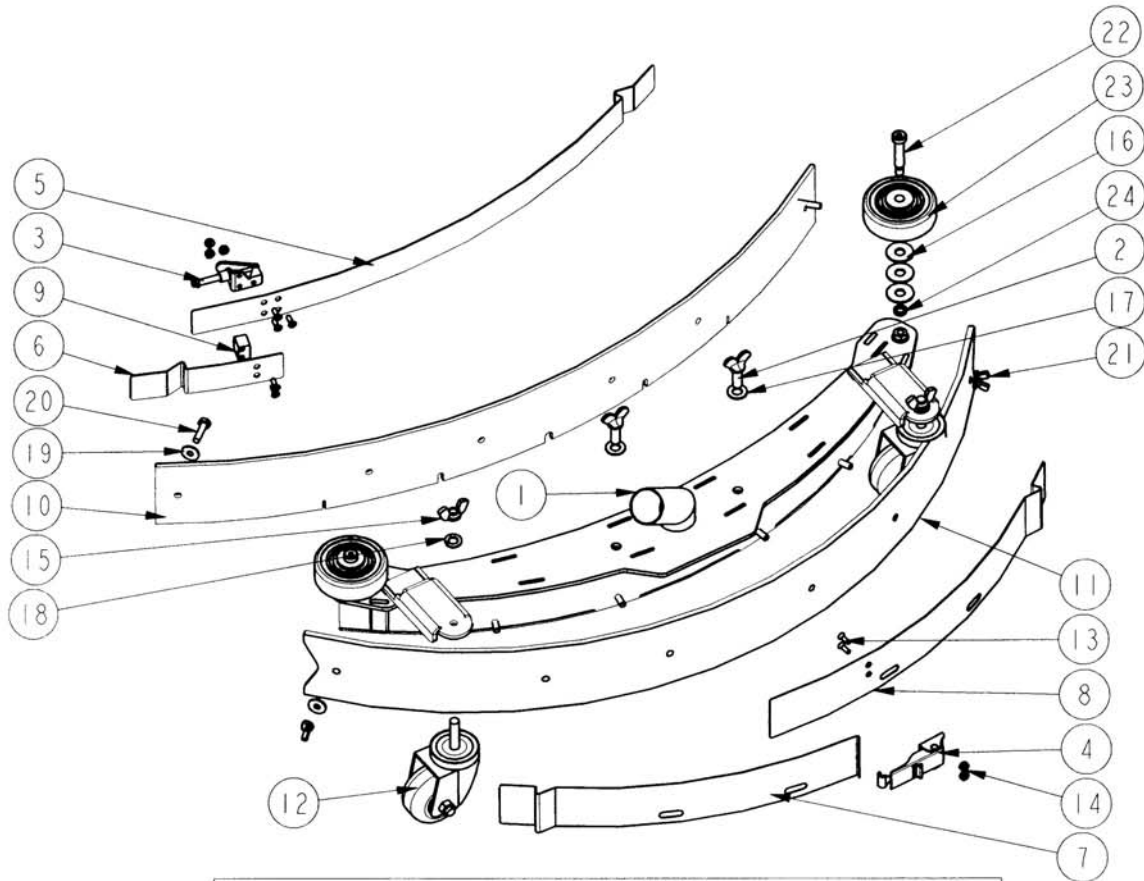

BILL OF MATERIAL			
ITEM	PART NO.	REQ'D	DESCRIPTION
1	241721	1	SQUEEGEE WMT ASS'Y, SCV 24/26
2	260206	2	WING BOLT 3/8-16 X 1.00 ST PL
3	281074	1	SQUEEGEE TOGGLE CLAMP, 2800
4	281075	1	SQUEEGEE LATCH, 2800
5	281732	1	STRAP - FRONT CLAMP
6	281734	1	STRAP - FRONT STOP
7	281736	1	STRAP - REAR CATCH
8	281738	1	STRAP - REAR LATCH
9	281740	1	STOP BAR
10	281763	1	PB FRONT BLADE, SQUEE GUM RUBBER
11	281764	1	PB REAR BLADE, SQUEEGEE GUM RUBBER
12	430325	2	CASTER 3/8"-16 X 1.50"
13	710530	7	SCR-MC FL HD 8-32 X .50 BRS
14	711026	5	NUT, HEX 8-32 NYLOC SS
15	711367	2	NUT- WING 3/8-16 ST PL
16	711507	6	WSR-FLAT .37 X 1.12 X .06
17	711515	2	WSR-FLAT .406 X .812 X .0625
18	711546	2	WSR-HELICAL 3/8
19	711550	4	WSR NYLON .25 ID X .75 OD
20	711560	2	SCREW-HH 1/4-20X1.00 NYLON
21	711563	2	NUT- WING 1/4-20 NYLON
22	712091	2	SHOULDER BLT 3/8 X 1.50
23	808829	2	WHEEL, TRUCK
24	832015	2	SPACER .38 X .50 X .140

BATTERY PANEL ASSEMBLY (LEFT HAND SIDE)

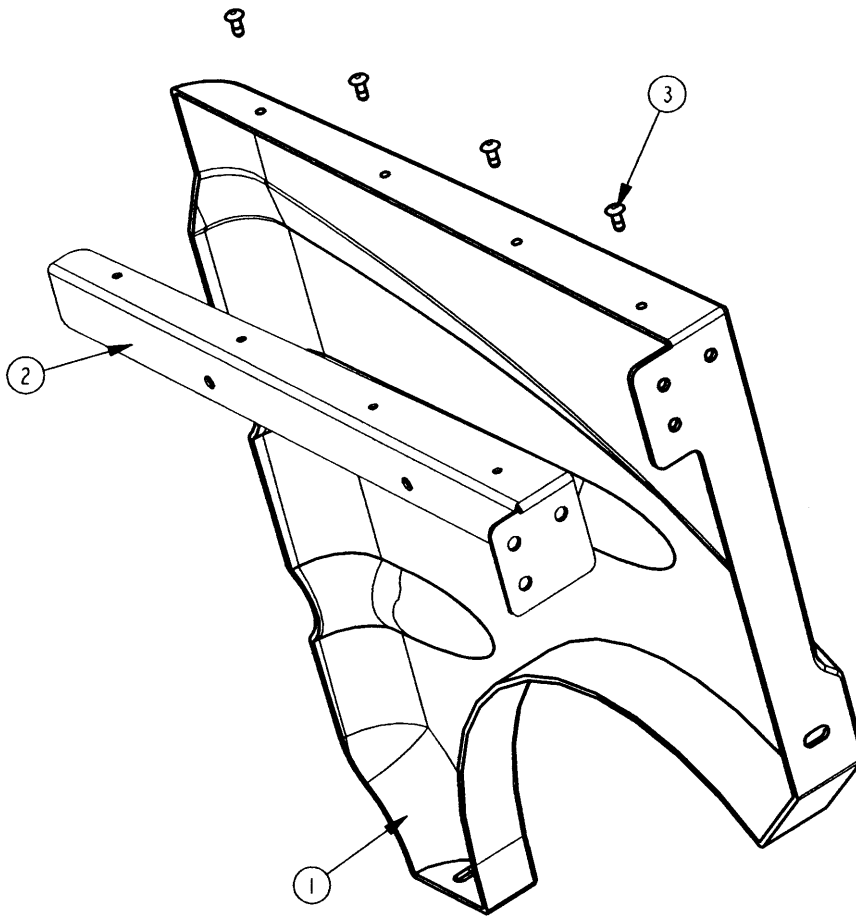

BILL OF MATERIAL			
ITEM	PART NO.	REQ'D	DESCRIPTION
1	241021	1	LH BATTERY PANEL, SCV 24/26
2	241043	1	LEFT SIDE PANEL SUPPORT BRKT, SCV 24/26
3	711923	4	POP RIVET 3/16"

BATTERY PANEL ASSEMBLY (RIGHT HAND SIDE)

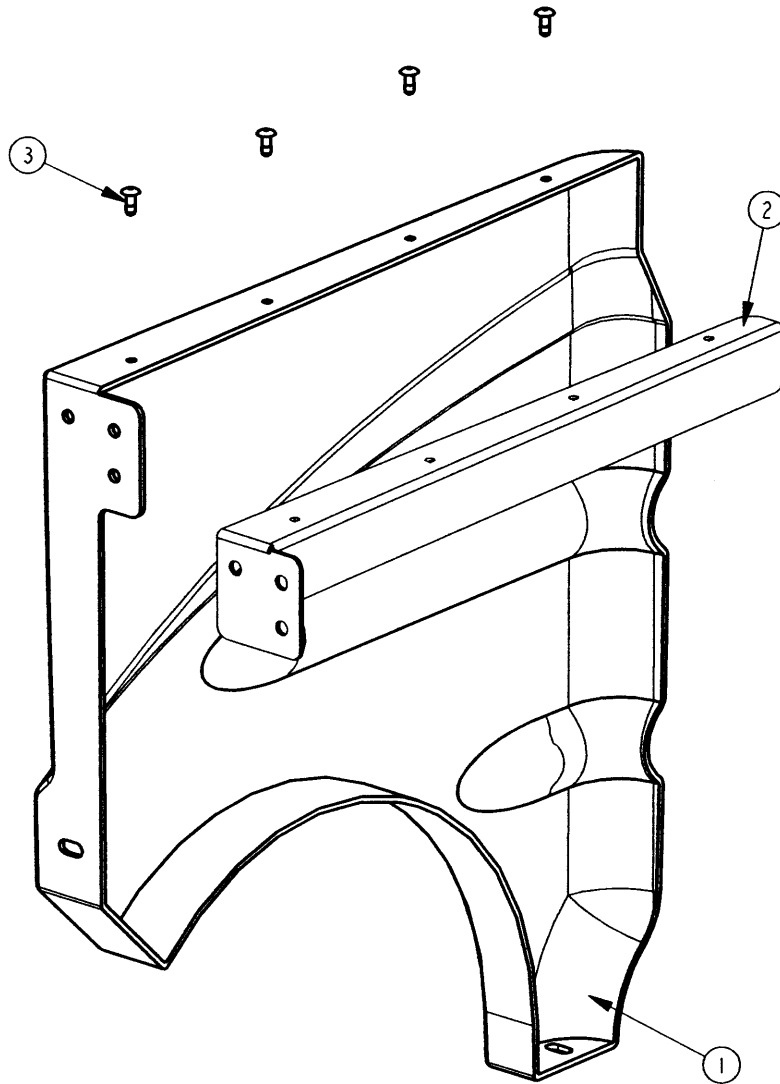

BILL OF MATERIAL			
ITEM	PART NO.	REQ'D	DESCRIPTION
1	241022	1	RH BATTERY PANEL, SCV 24/26
2	241044	1	RIGHT SIDE PANEL SUPPORT BRKT, SCV 24/26
3	711923	4	POP RIVET 3/16"

24" CYLINDRICAL SCRUB DECK ASSEMBLY I (ITEMS 1 - 35)

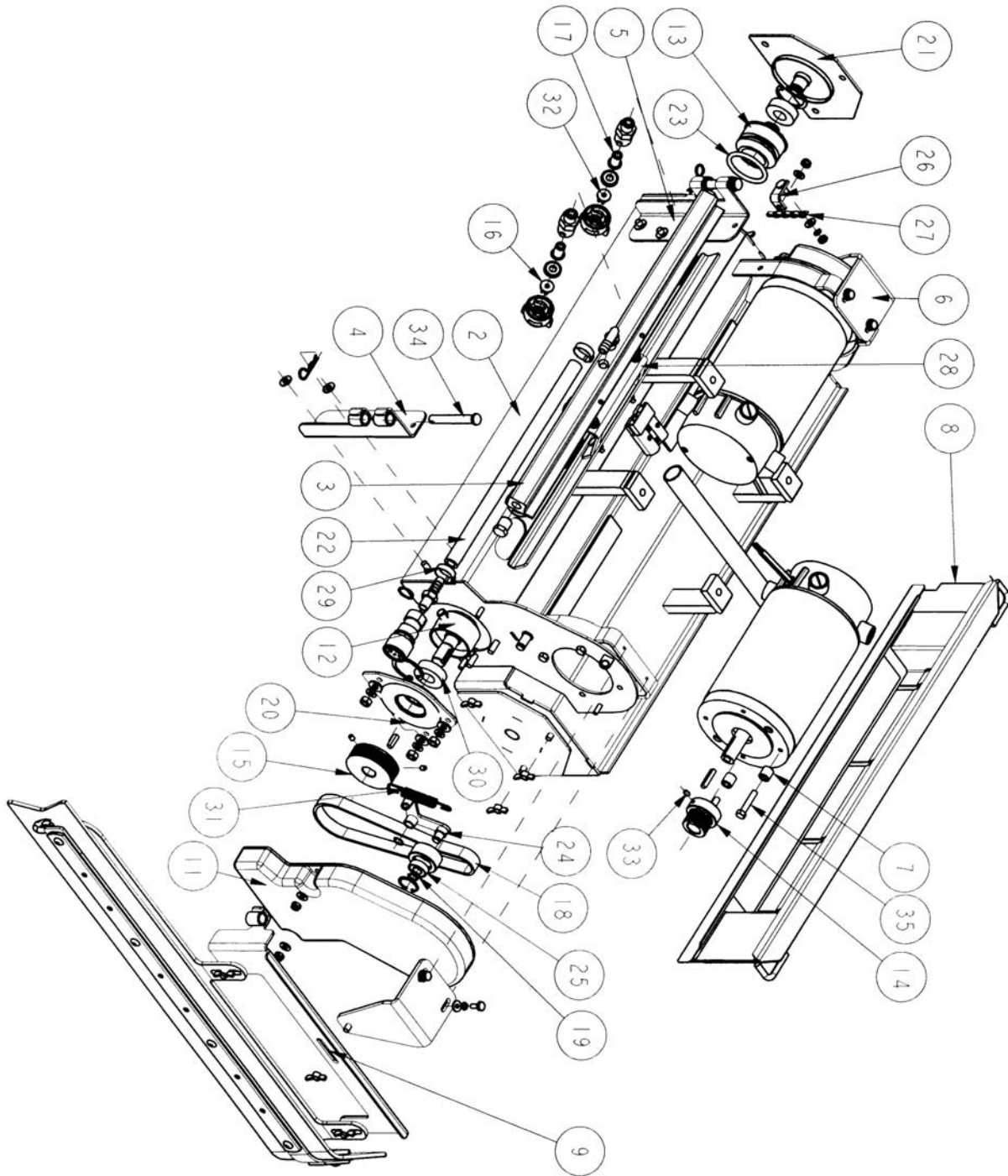

24" CYLINDRICAL SCRUB DECK ASSEMBLY II (ITEMS 36 – 65)

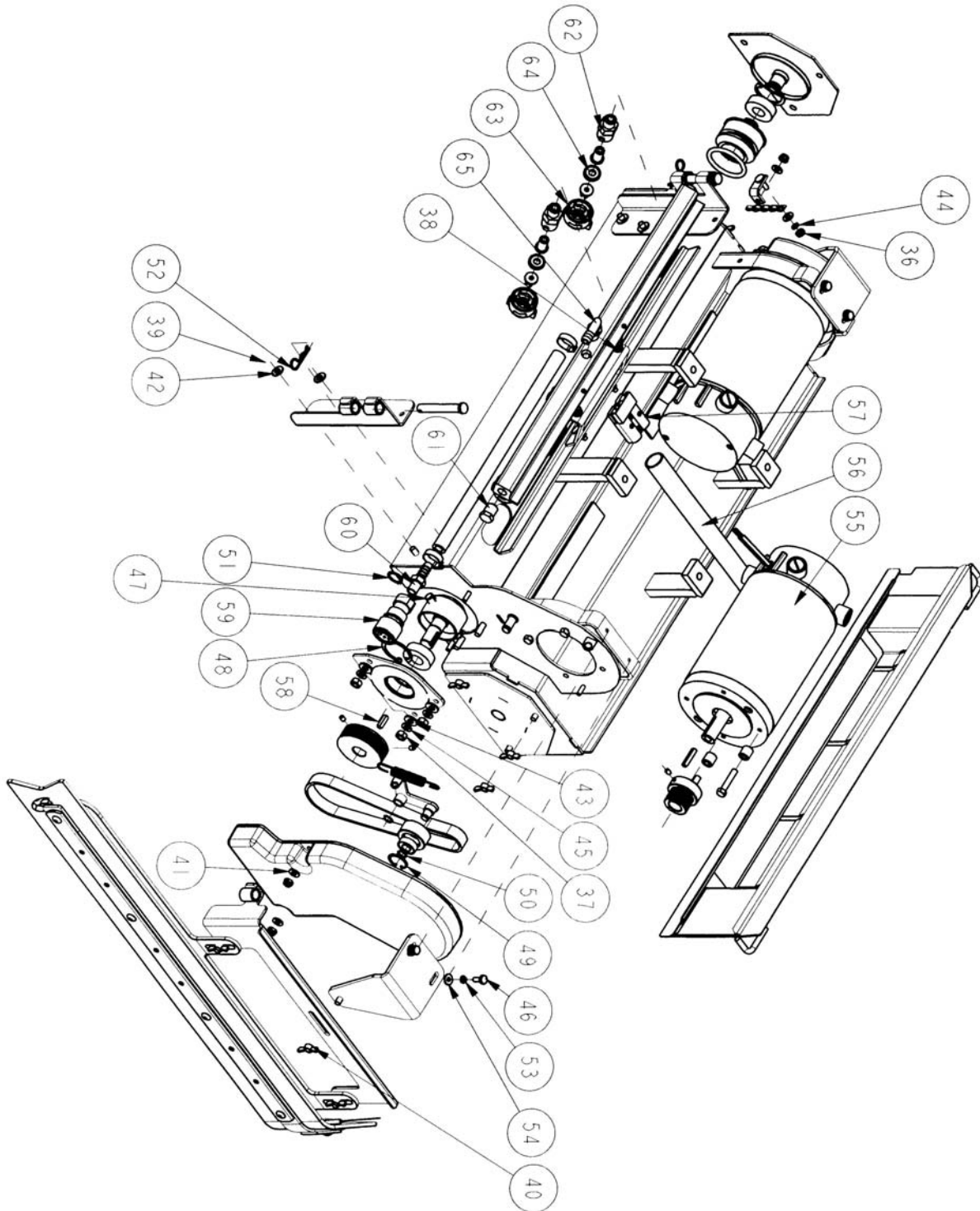

24" CYLINDRICAL SCRUBDECK BOM (SEE ASSEMBLY I & II)

BILL OF MATERIAL - 241702							
ITEM	PART NO.	QTY	DESCRIPTION	ITEM	PART NO.	QTY	DESCRIPTION
1	000730	1	THD SEAL L567-47/LH150	34	711119	2	CLEVIS PIN 7/16 X 2-5/8
2	241502	1	CYL SCRUBDECK WELDMENT, SCV 24	35	711210	8	BLT-HH 1/4-20 X 1.25 STPL
3	241512	1	SPRAY BAR, CYL SCRUBDECK, SCV 24/26	36	711310	1	NUT, HEX 10-32 ST PL
4	241514	1	HINGE BRKT WLDMT LH, SCV2426	37	711316	6	NUT-HEX 1/4-20 ST PL
5	241516	1	HINGE BRKT WLDMT RH, SCV2426	38	711350	10	NUT NYLOC 10-32
6	241518	2	CYL SCRUBDECK PIVOT PLATE, SCV24	39	711373	4	NUT-NYLOC 1/4-20
7	241598	8	MOTOR SPACER CYL DECK, SCV 24/26	40	711389	8	NUT-WING 1/4-20 STL ZINC
8	241901	1	DEBRIS BOX WMT, CYL SCRUBDECK 24"	41	711503	9	WSR, FLAT#10
9	241911	1	SIDE SQUEEGEE ASSY LH, SCV 24/26	42	711504	4	WSR-FLAT 1/4 ID SS
10	241912	1	SIDE SQUEEGEE ASSY RH, SCV 24/26	43	711505	6	WSR-FLAT 1/4
11	281023	2	BELT COVER, CYLINDRICAL SCRUBDECK	44	711543	1	WSR - HELICAL #10
12	281034	2	DRIVE HUB, CYLINDRICAL SCRUBDECK	45	711544	6	WSR-HELICAL 1/4
13	281035	2	IDLE HUB, CYLINDRICAL SCRUBDECK	46	711623	4	SCR-MC IND. HH 10-24 X .50 STPL
14	281036	2	OFFSET PULLEY POLY V	47	711676	4	ROLL PIN, 3/8 x 3/4
15	281037	2	DRIVEN PULLEY	48	711701	4	RETAINING RING, INT 1.37
16	281040	2	SPRAY TIP 11005	49	711704	2	INTERNAL RETAINING RING N5000-86 .875 DIA.
17	281041	4	CHECK VALVE	50	711724	4	3/8" RETAINING RING, EXTERNAL
18	281053	2	J BELT (POLY V) 18"	51	711725	4	5/8" RETAINING RING, EXTERNAL
19	281058	2	BEARING 3/8" RADIAL	52	711808	2	COTTER PIN-HAIR #13
20	281505	2	BRUSH DRIVE HUB WMT	53	712757	4	WSR - HELICAL #10 SS
21	281512	2	IDLE SHAFT WMT	54	712764	4	WSR #10 SS
22	281517	1	SOL FEED HOSE, 28" CYL DECK	55	748102	2	MOTOR 3/4 HP, 36V, 1800RPM
23	281519	2	O-RING 1.62 X 2.00 X .188	56	748141	1	CABLE WRAP, 11"
24	281544	2	TENSIONER ARM WELDMT	57	748215	1	CIRCUIT BRKR - SB50 GRAY HOUSING ONLY
25	281548	2	BELT IDLER	58	760043	2	KEY, 3/16 X .675 L
26	281557	1	DRAG CHAIN BRKT, CYL. SCRUBDECK	59	828370	1	1/4 NPT SOCKET FEMALE END COUPLI
27	281558	1	DRAG CHAIN, CYL. SCRUBDECK	60	828952	1	FITTING PP 1/4" MPT X 3/8" HOSE BARB
28	281606	1	SPRAY HEAD MTG BRKT, 28" & 32"	61	829619	2	END PLUG
29	383347	2	CRIMP CLAMP 1/2 HOSE SS 185R	62	833140	4	BODY INLET CONNECTOR
30	383582	4	BALL BEARING, RADIAL 5/8"	63	833141	4	CAP
31	430051	2	RETURN SPRING-3.00"	64	833142	4	GASKET CAP
32	450122	2	UNIJET SPRAY TIP 6503	65	833325	1	FITTING NYLON 90 1/4MPT X 3/8HB
33	711003	8	SCR-SK 10-32 x .25				

26" CYLINDRICAL SCRUB DECK ASSEMBLY I (ITEMS 1 - 35)

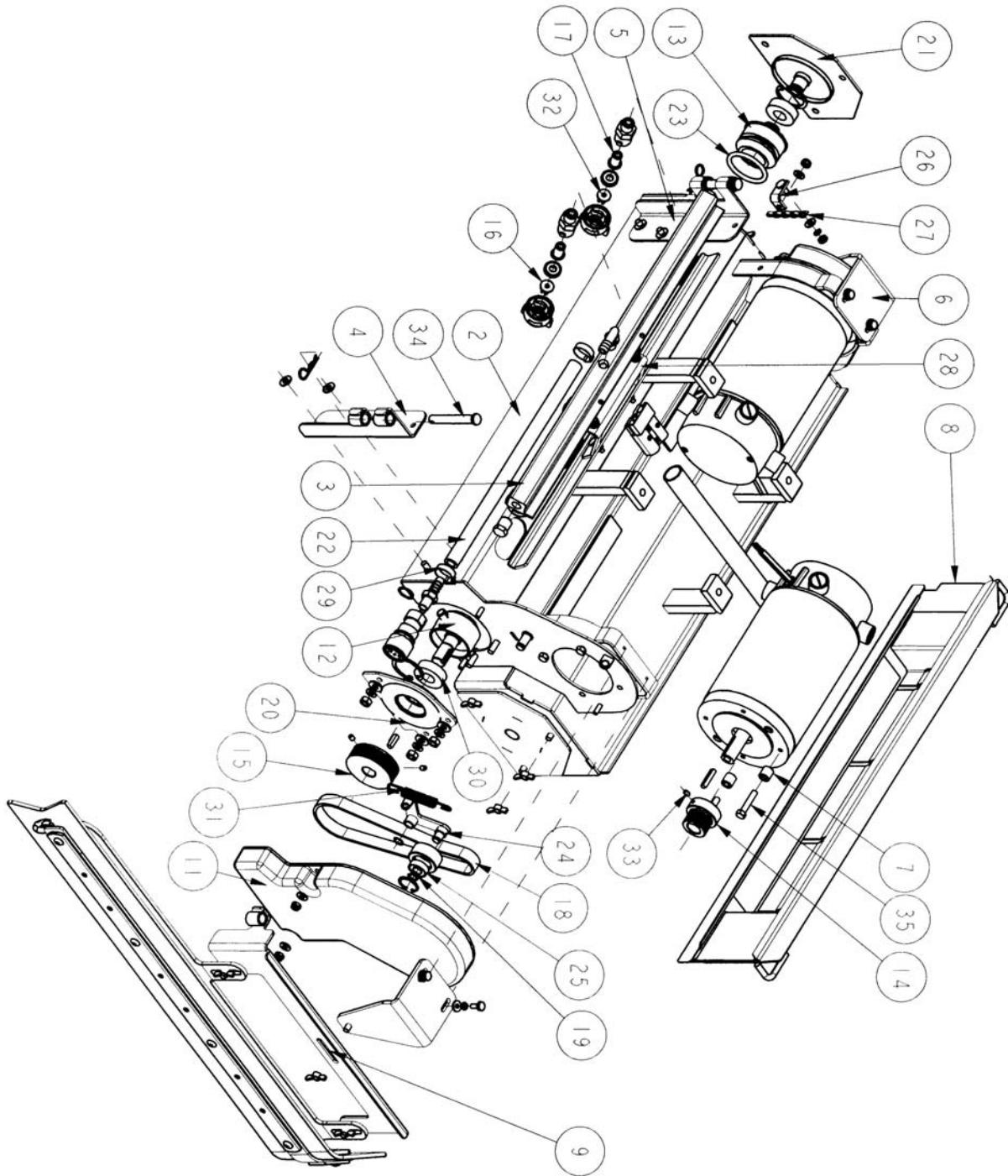

26" CYLINDRICAL SCRUBDECK BOM (SEE ASSEMBLY I & II)

BILL OF MATERIAL - 241703							
ITEM	PART NO.	QTY	DESCRIPTION	ITEM	PART NO.	QTY	DESCRIPTION
1	000730	1	THD SEAL L567-47/LH150	34	711119	2	CLEVIS PIN 7/16 X 2-5/8
2	241503	1	CYLINDRICAL SCRUBDECK WELDMENT, SCV 26	35	711210	8	BLT-HH 1/4-20 X 1.25 STPL
3	241512	1	SPRAY BAR, CYL SCRUBDECK, SCV 24/26	36	711310	1	NUT, HEX 10-32 ST PL
4	241514	1	HINGE BRKT WLDMT LH, SCV2426	37	711316	6	NUT-HEX 1/4-20 ST PL
5	241516	1	HINGE BRKT WLDMT RH, SCV2426	38	711350	10	NUT NYLOC 10-32
6	241518	2	CYL SCRUBDECK PIVOT PLATE, SCV24	39	711373	4	NUT-NYLOC 1/4-20
7	241598	8	MOTOR SPACER CYL DECK, SCV 24/26	40	711389	8	NUT-WING 1/4-20 STL ZINC
8	241961	1	DEBRIS BOX WMT, CYL SCRUBDECK 26"	41	711503	9	WSR, FLAT#10
9	241911	1	SIDE SQUEEGEE ASSY LH, SCV 24/26	42	711504	4	WSR-FLAT 1/4 ID SS
10	241912	1	SIDE SQUEEGEE ASSY RH, SCV 24/26	43	711505	6	WSR-FLAT 1/4
11	281023	2	BELT COVER, CYLINDRICAL SCRUBDECK	44	711543	1	WSR - HELICAL #10
12	281034	2	DRIVE HUB, CYLINDRICAL SCRUBDECK	45	711544	6	WSR-HELICAL 1/4
13	281035	2	IDLE HUB, CYLINDRICAL SCRUBDECK	46	711623	4	SCR-MC IND. HH 10-24 X .50 STPL
14	281036	2	OFFSET PULLEY POLY V	47	711676	4	ROLL PIN, 3/8 x 3/4
15	281037	2	DRIVEN PULLEY	48	711701	4	RETAINING RING, INT 1.37
16	281040	2	SPRAY TIP 11005	49	711704	2	INTERNAL RETAINING RING N5000-86 .875 DIA.
17	281041	4	CHECK VALVE	50	711724	4	3/8" RETAINING RING, EXTERNAL
18	281053	2	J BELT (POLY V) 18"	51	711725	4	5/8" RETAINING RING, EXTERNAL
19	281058	2	BEARING 3/8" RADIAL	52	711808	2	COTTER PIN-HAIR #13
20	281505	2	BRUSH DRIVE HUB WMT	53	712757	4	WSR - HELICAL #10 SS
21	281512	2	IDLE SHAFT WMT	54	712764	4	WSR #10 SS
22	281517	1	SOL FEED HOSE, 28" CYL DECK	55	748102	2	MOTOR 3/4 HP, 36V, 1800RPM
23	281519	2	O-RING 1.62 X 2.00 X .188	56	748141	1	CABLE WRAP, 11"
24	281544	2	TENSIONER ARM WELDMT	57	748215	1	CIRCUIT BRKR - SB50 GRAY HOUSING ONLY
25	281548	2	BELT IDLER	58	760043	2	KEY, 3/16 X .675 L
26	281557	1	DRAG CHAIN BRKT, CYL, SCRUBDECK	59	828370	1	1/4 NPT SOCKET FEMALE END COUPLI
27	281558	1	DRAG CHAIN, CYL, SCRUBDECK	60	828952	1	FITTING PP 1/4" MPT X 3/8" HOSE BARB
28	281606	1	SPRAY HEAD MTG BRKT, 28" & 32"	61	829619	2	END PLUG
29	383347	2	CRIMP CLAMP 1/2 HOSE SS 185R	62	833140	4	BODY INLET CONNECTOR
30	383582	4	BALL BEARING, RADIAL 5/8"	63	833141	4	CAP
31	430051	2	RETURN SPRING-3.00"	64	833142	4	GASKET CAP
32	450122	2	UNIJET SPRAY TIP 6503	65	833325	1	FITTING NYLON 90 1/4MPT X 3/8HB
33	711003	8	SCR-SK 10-32 x .25				

24" DISC SCRUB DECK ASSEMBLY I

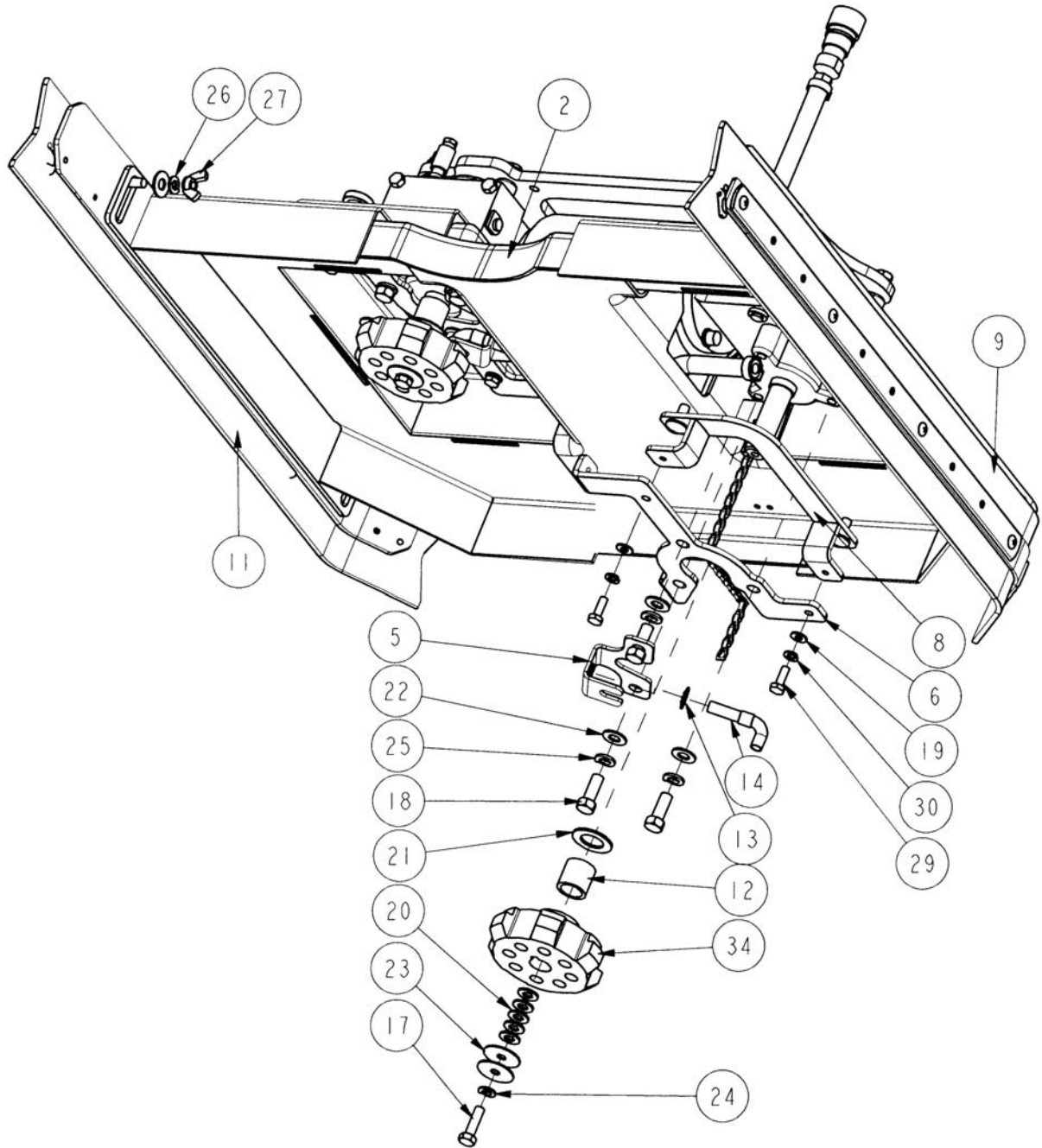

24" DISC SCRUB DECK ASSEMBLY II

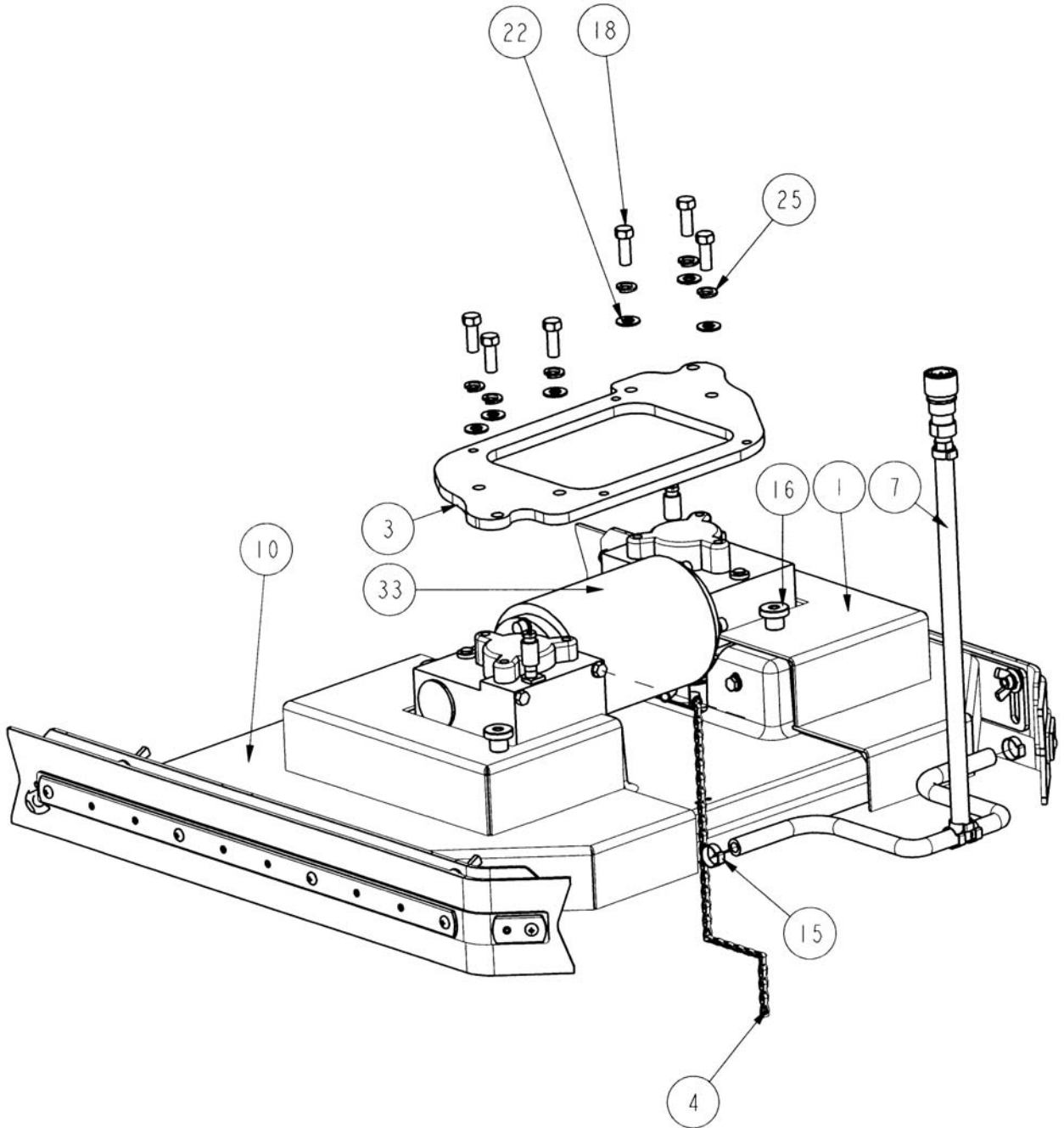

24" DISC SCRUB DECK BOM (SEE ASSEMBLY I & II)

Bill of Material - 241601			
ITEM	PART NO.	QTY	DESCRIPTION
1	241603	1	RH DISK DECK COVER, SCV2426
2	241605	1	MOTOR SHROUD 24" DECK
3	241610	1	DISK SCRUBDECK MNTG PLATE, 24"
4	241628	1	DRAG CHAIN ASSY, DISK SCRUBDECK SCV 24/26
5	241653	2	WATER FEED BRKT, DISK, SCV24/26
6	241657	2	MOUNTING BRACKET, MOTOR COVER
7	241661	1	SOL. FEED HOSE SUB-ASS'Y, DISK
8	241662	2	COVER MNT BRK'T, SCV 24/26 ASSY
9	241674	1	SIDE SQUEEGEE WIPE ASSY LH, SCV 24/26
10	241685	1	LH DISK DECK COVER, SCV 2426
11	241687	1	SIDE SQUEEGEE WIPE ASSY RH, SCV 24/26
12	281611	2	HUB-SCRUB SPACER TUBE
13	281633	2	SPEED NUT - 3/8"
14	281634	2	DISK SOLUTION FEED ASSY
15	450076	2	CRIMP CLAMP SS 185R
16	711029	4	KNOB, 5/16-18 KNURLED
17	711231	2	BLT-HH 5/16-18X1.25 ST PL
18	711242	12	BLT-HEX 3/8 -16X1.00 ZP
19	711504	11	WSR-FLAT 1/4 ID SS
20	711506	10	WSR-FLT .344 X .690 X .062 STL ZINC
21	711512	2	WSR-FLAT .75X1.37X.08
22	711515	12	WSR-FLAT .406 X .812 X .0625
23	711516	3	WSR- FLAT .31 X 1.25 X .05
24	711545	2	WSR-HELICAL 5/16
25	711546	12	WSR-HELICAL 3/8
26	712140	4	WSR-HELICAL 5/16 SS
27	712157	4	NUT- WING 5/16-18 SS
28	712301	4	WSR-FLAT .87 X .38 X .06
29	712562	8	BOLT-HH 1/4-20X3/4 SS
30	712758	8	WSR-HELICAL 1/4 SS
31	740099	3	CABLE TIE - SMALL
32	748141	1	CABLE WRAP, 11"
33	748210-1	1	DUAL RIGHT ANGLE MOTOR 24" ASSY
34	3312402	2	HUB-SCRUB BRUSH DRIVE

26" DISC SCRUB DECK ASSEMBLY I

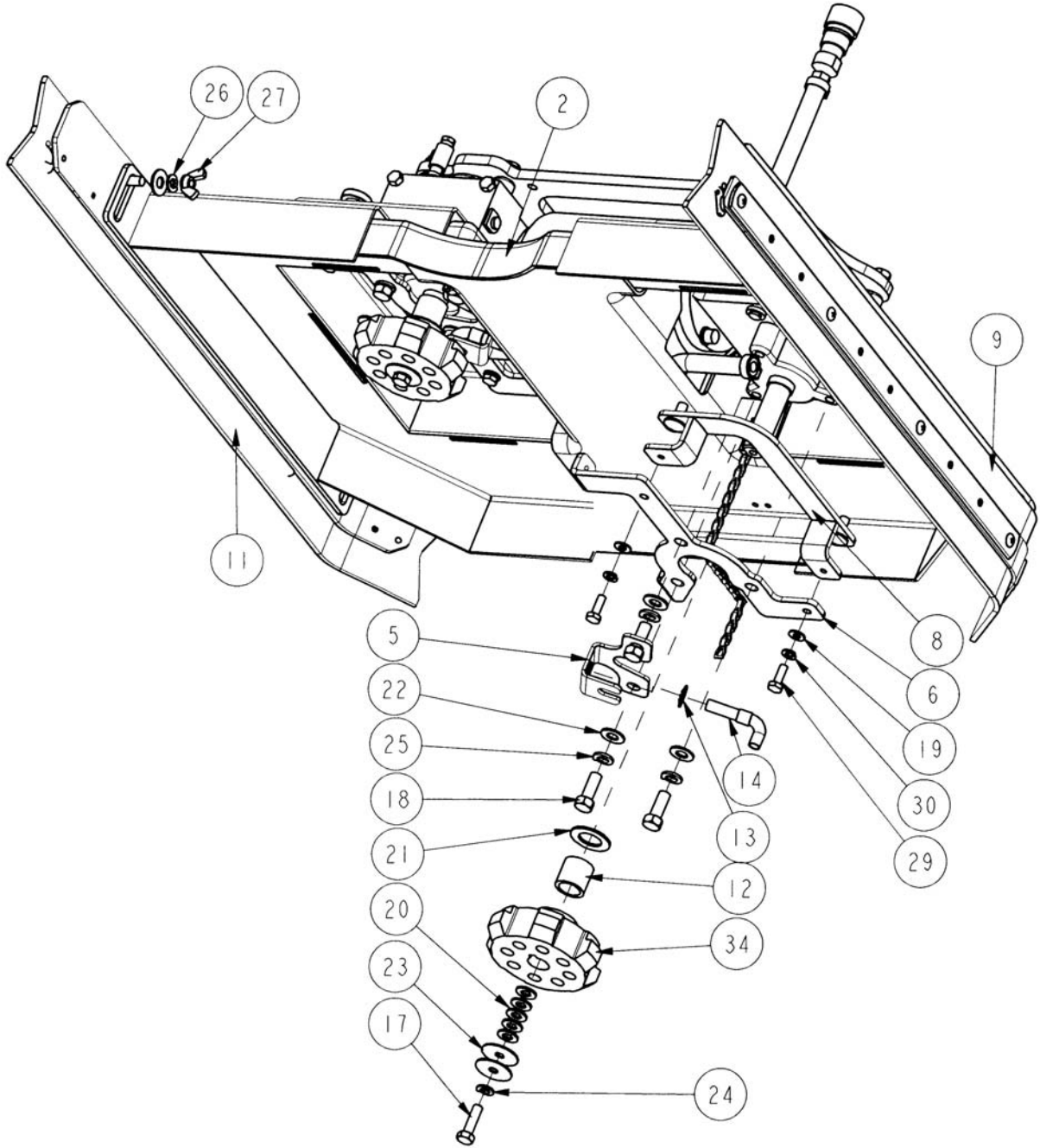

26" DISC SCRUB DECK ASSEMBLY II

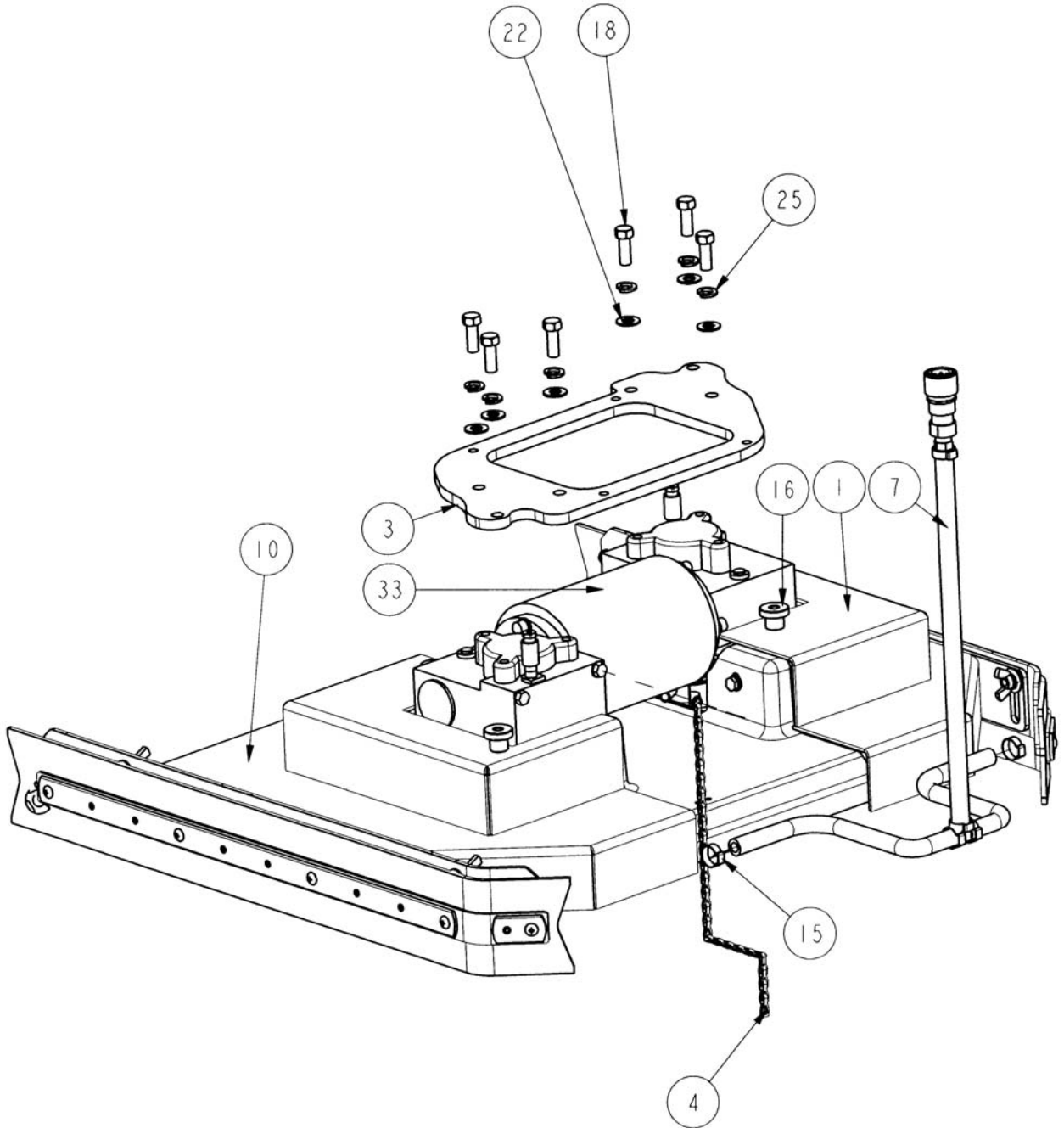

26" DISC SCRUB DECK BOM (SEE ASSEMBLY I & II)

Bill of Material - 241651			
ITEM	PART NO.	REQ'D	DESCRIPTION
1	241603	1	RH DISK DECK COVER, SCV2426
2	241655	1	MOTOR SHROUD 26" DECK
3	241660	1	DISK SCRUBDECK MNTG PLATE, 26"
4	241628	1	DRAG CHAIN ASSY, DISK SCRUBDECK SCV 24/26
5	241653	2	WATER FEED BRKT, DISK, SCV24/26
6	241657	2	MOUNTING BRACKET, MOTOR COVER
7	241661	1	SOL. FEED HOSE SUB-ASS'Y, DISK
8	241662	2	COVER MNT BRK'T, SCV 24/26 ASSY
9	241674	1	SIDE SQUEEGEE WIPE ASSY LH, SCV 24/26
10	241685	1	LH DISK DECK COVER, SCV 2426
11	241687	1	SIDE SQUEEGEE WIPE ASSY RH, SCV 24/26
12	281611	2	HUB-SCRUB SPACER TUBE
13	281633	2	SPEED NUT - 3/8"
14	281634	2	DISK SOLUTION FEED ASSY
15	450076	2	CRIMP CLAMP SS 185R
16	711029	4	KNOB, 5/16-18 KNURLED
17	711231	2	BLT-HH 5/16-18X1.25 ST PL
18	711242	12	BLT-HEX 3/8 -16X1.00 ZP
19	711504	11	WSR-FLAT 1/4 ID SS
20	711506	10	WSR-FLT .344 X .690 X .062 STL ZINC
21	711512	2	WSR-FLAT .75X1.37X.08
22	711515	12	WSR-FLAT .406 X .812 X .0625
23	711516	3	WSR- FLAT .31 X 1.25 X .05
24	711545	2	WSR-HELICAL 5/16
25	711546	12	WSR-HELICAL 3/8
26	712140	4	WSR-HELICAL 5/16 SS
27	712157	4	NUT- WING 5/16-18 SS
28	712301	4	WSR-FLAT .87 X .38 X .06
29	712562	8	BOLT-HH 1/4-20X3/4 SS
30	712758	8	WSR-HELICAL 1/4 SS
31	740099	3	CABLE TIE - SMALL
32	748141	1	CABLE WRAP, 11"
33	748211-1	1	DUAL RIGHT ANGLE MOTOR 26" ASSY
34	3312402	2	HUB-SCRUB BRUSH DRIVE

CYLINDRICAL SIDE SQUEEGEE (LEFT SIDE)

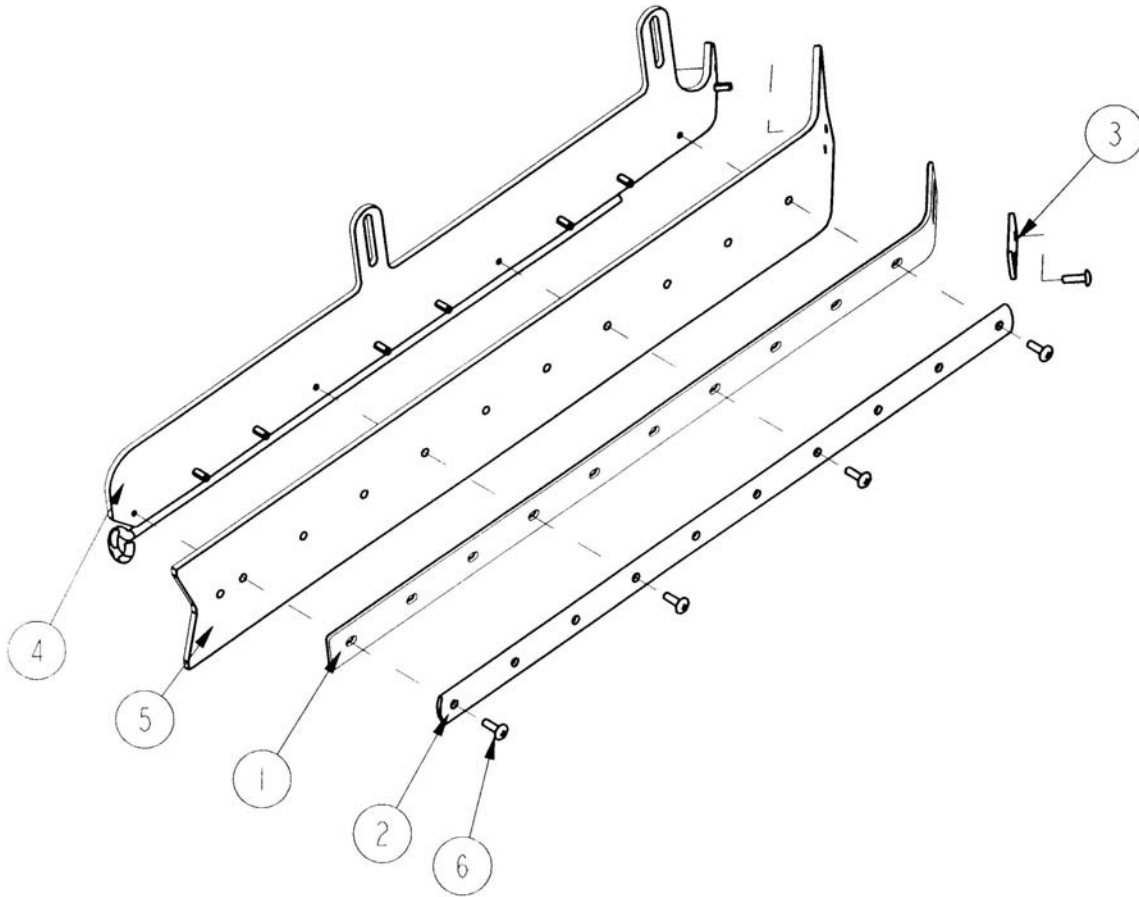

BILL OF MATERIAL - 241915			
ITEM	PART NO.	REQ'D	DESCRIPTION
1	241678	1	BACKER BLADE, LONG SCV 24/26
2	241679	1	LONG RETAINER, SIDE SQ SCV2426
3	241680	1	SHORT RETAINER, SIDE SQ SCV2426
4	241917	1	SIDE SQUEEGEE SUB-ASSY LH, SCV 24/26
5	241925	1	SIDE SQUEEGEE BLADE LINATEX, SCV 24/26
6	710154	5	SCR-MC TR HD 10-32 X .625 SS

CYLINDRICAL SIDE SQUEEGEE (RIGHT SIDE)

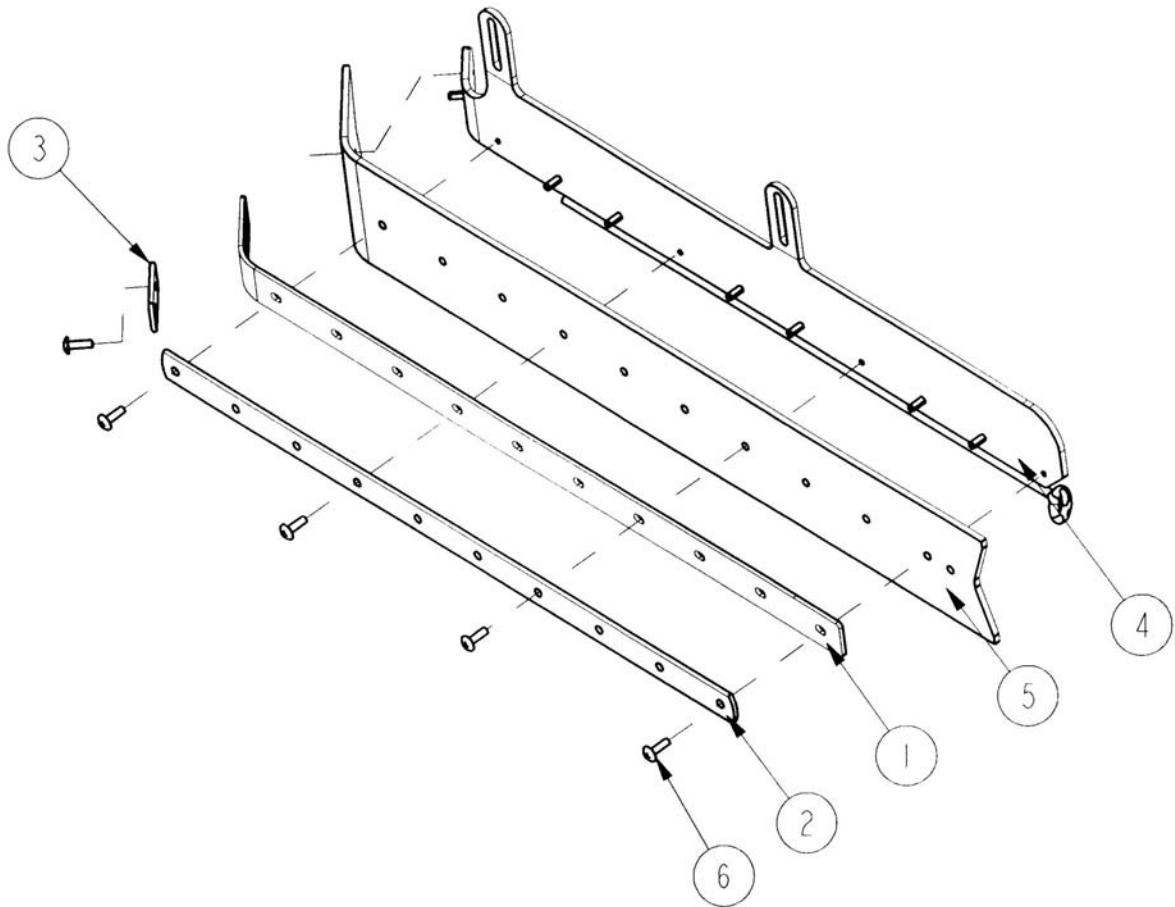

BILL OF MATERIAL - 241916			
ITEM	PART NO.	REQ'D	DESCRIPTION
1	241678	1	BACKER BLADE, LONG SCV 24/26
2	241679	1	LONG RETAINER, SIDE SQ SCV2426
3	241680	1	SHORT RETAINER, SIDE SQ SCV2426
4	241918	1	SIDE SQUEEGEE SUB-ASSY RH, SCV 24/26
5	241925	1	SIDE SQUEEGEE BLADE LINATEX, SCV 24/26
6	710154	5	SCR-MC TR HD 10-32 X .625 SS

DISK SIDE SQUEEGEE (LEFT SIDE)

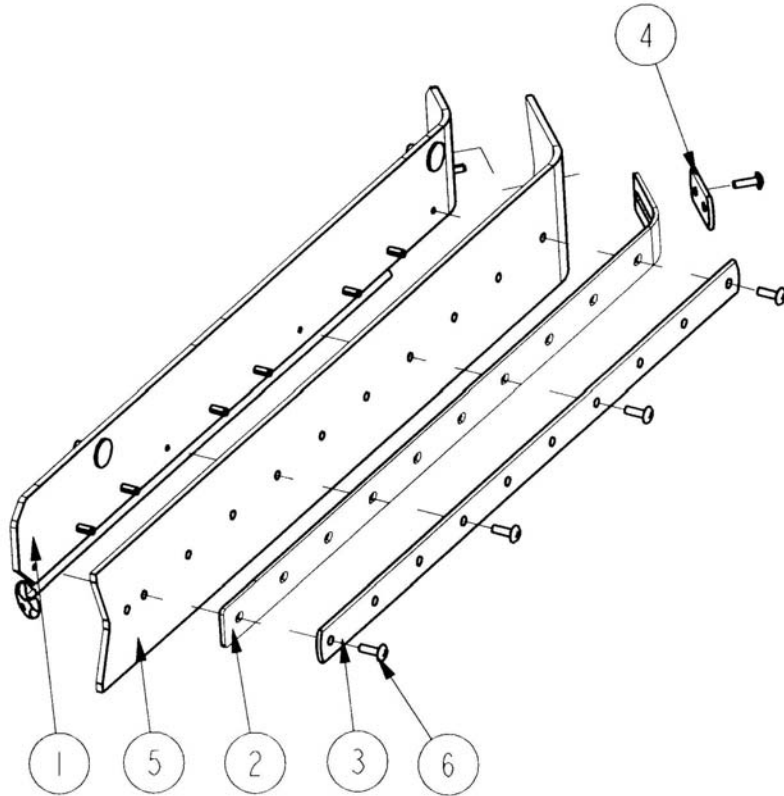

BILL OF MATERIAL - 241674			
ITEM	PART NO.	REQ'D	DESCRIPTION
1	241675	1	DISK SQUEEGEE SUBASSY LH, SCV2426
2	241678	1	BACKER BLADE, LONG SCV 24/26
3	241679	1	LONG RETAINER, SIDE SQ SCV2426
4	241680	1	SHORT RETAINER, SIDE SQ SCV2426
5	241925	1	SIDE SQUEEGEE BLADE LINATEX, SCV 24/26
6	710154	5	SCR-MC TR HD 10-32 X .625 SS

DISC SIDE SQUEEGEE (RIGHT SIDE)

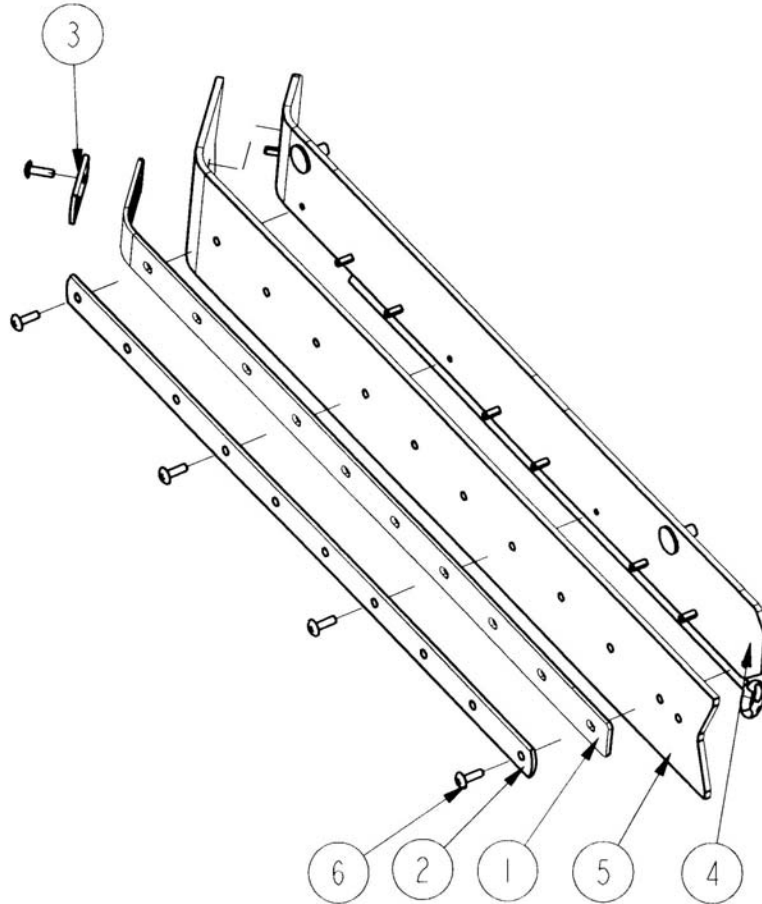

BILL OF MATERIAL - 241687			
ITEM	PART NO.	REQ'D	DESCRIPTION
1	241678	1	BACKER BLADE, LONG SCV 24/26
2	241679	1	LONG RETAINER, SIDE SQ SCV2426
3	241680	1	SHORT RETAINER, SIDE SQ SCV2426
4	241688	1	DISK SQUEEGEE SUBASSY RH, SCV2426
5	241925	1	SIDE SQUEEGEE BLADE LINATEX, SCV 24/26
6	710154	5	SCR-MC TR HD 10-32 X .625 SS

24" CYLINDRICAL BRUSH ASSEMBLY

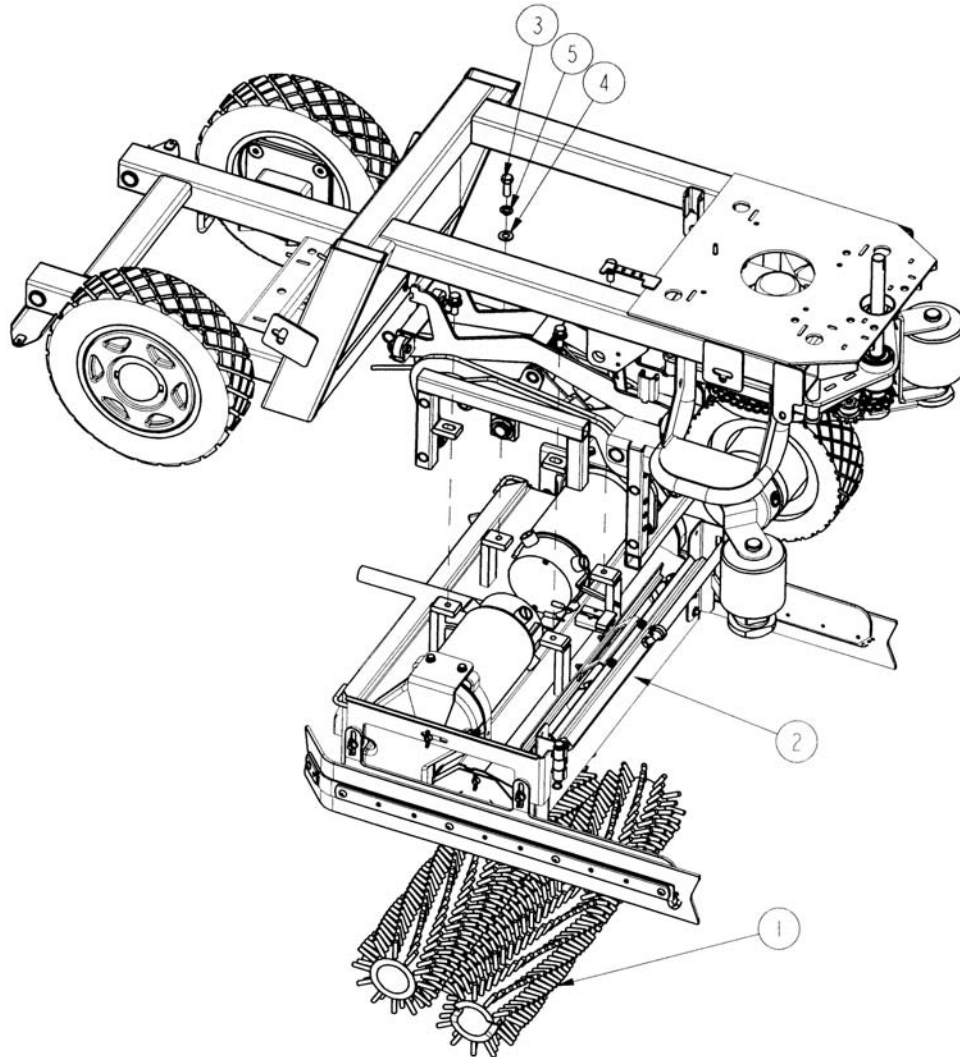

BILL OF MATERIAL			
ITEM	PART NO.	REQ'D	DESCRIPTION
1	241520	2	BRUSH, CYL 24" .022 NYLON
1A	241521	2	BRUSH, CYL 24" .028 NYLON
1B	241522	2	BRUSH, CYL 24" .026 PP
1C	241523	2	BRUSH, CYL 24" .028 PP
1D	241524	2	BRUSH, CYL 24" DYNASCRUB 500GR
1E	241525	2	BRUSH, CYL 24" POWERSCRUB 120GR
1F	241526	2	BRUSH, CYL 24" NYLOGRIT 80GR
1G	241527	2	BRUSH, CYL 24" STRATAGRIT 46GR
1H	241528	2	BRUSH, CYL 24" STRGRIT PLUS 36
1I	241529	2	BRUSH, CYL 24" 180 GR
2	241702	1	24" CYL DECK WITH SIDE SQUEEGEES, SCV 24/26
3	711242	4	BLT-HEX 3/8 -16X1.00 ZP
4	711515	4	WSR-FLAT .406 X .812 X .0625
5	711546	4	WSR-HELICAL 3/8

24" DISC BRUSH ASSEMBLY

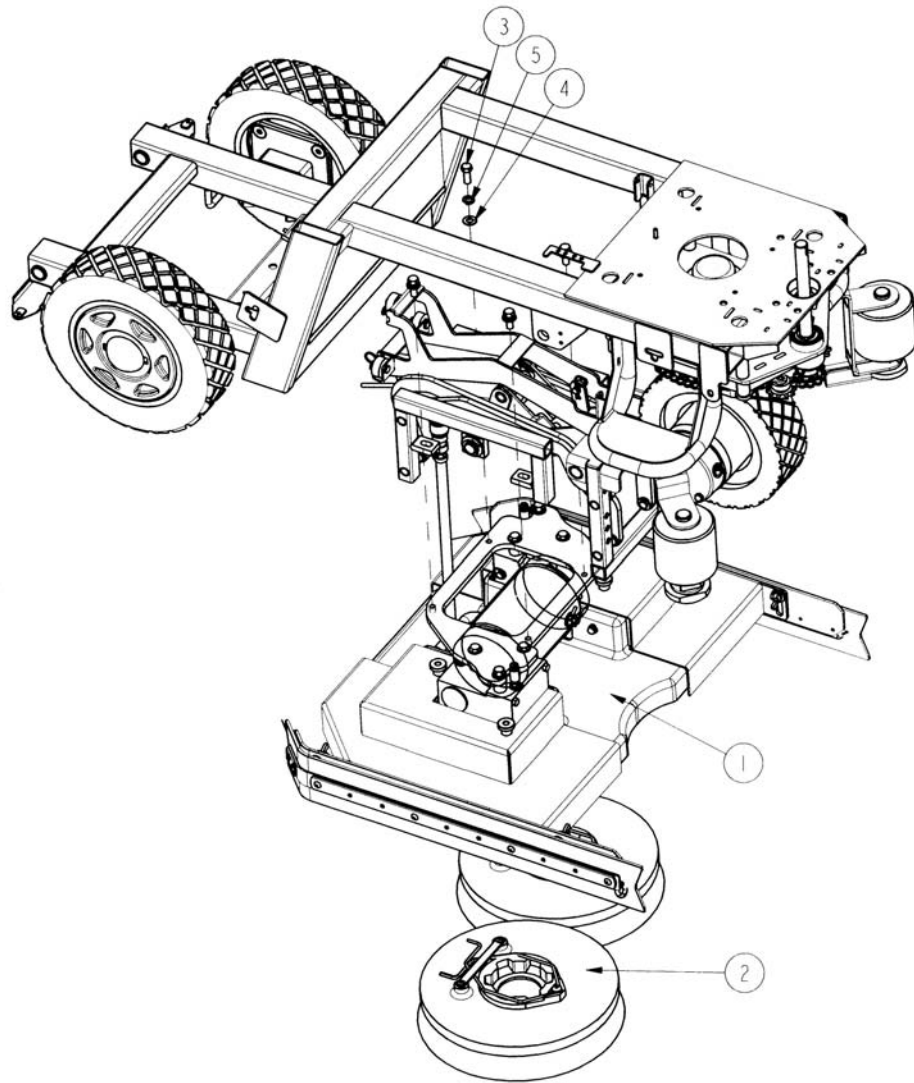

BILL OF MATERIAL			
ITEM	PART NO.	REQ'D	DESCRIPTION
1	241601	1	DISK SCRUBDECK, 24"
2	241620	2	12" SCRUB BRUSH .022 NYLON
2A	241618	2	BRUSH-12" PWR DRIVE W/PAD HOLDER
2B	241621	2	12" SCRUB BRUSH .028 NYLON
2C	241622	2	12" SCRUB BRUSH DYNASCRUB 500GR
2D	241623	2	12" SCRUB BRUSH POWERSCRUB 120GR
2E	241624	2	12" SCRUB BRUSH NYLOGRIT 80GR
2F	241625	2	12" SCRUB BRUSH STRATAGRIT 46GR
2H	241626	2	12" SCRUB BRUSH 180 GR
3	711242	4	BLT-HEX 3/8 -16X1.00 ZP
4	711515	4	WSR-FLAT .406 X .812 X .0625
5	711546	4	WSR-HELICAL 3/8

26" CYLINDRICAL BRUSH ASSEMBLY

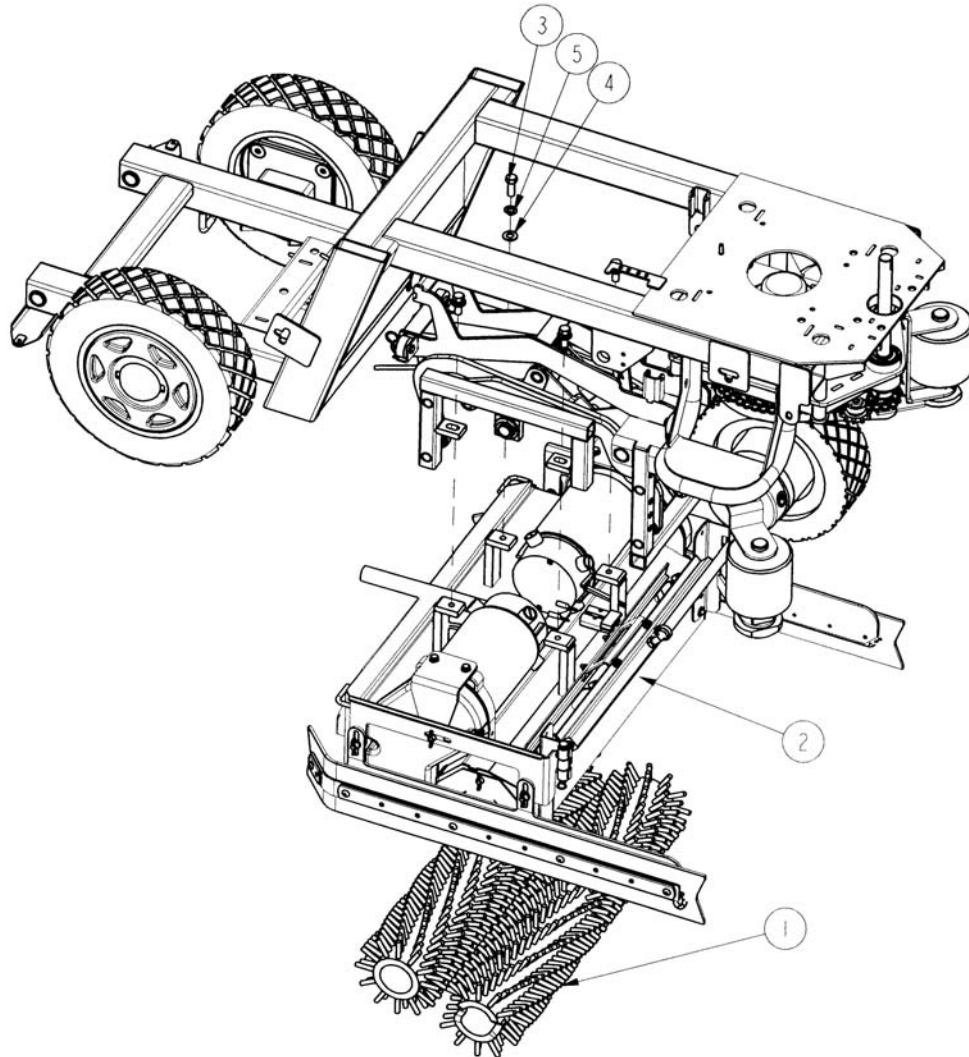

BILL OF MATERIAL			
ITEM	PART NO.	REQ'D	DESCRIPTION
1	241530	2	BRUSH, CYL 26" .022 NYLON
1A	241531	2	BRUSH, CYL 26" .028 NYLON
1B	241532	2	BRUSH, CYL 26" .026 PP
1C	241533	2	BRUSH, CYL 26" .028 PP
1D	241534	2	BRUSH, CYL 26" DYNASCUB 500GR
1E	241535	2	BRUSH, CYL 26" POWERSCRUB 120GR
1F	241536	2	BRUSH, CYL 26" NYLOGRIT 80GR
1G	241537	2	BRUSH, CYL 26" STRATAGRIT 46GR
1H	241538	2	BRUSH, CYL 26" STRGRIT PLUS 36R
1I	241529	2	BRUSH, CYL 24" 180 GR
2	241703	1	26" CYL DECK WITH SIDE SQUEEGEES
3	711242	4	BLT-HEX 3/8 -16X1.00 ZP
4	711515	4	WSR-FLAT .406 X .812 X .0625
5	711546	4	WSR-HELICAL 3/8

26" DISC BRUSH ASSEMBLY

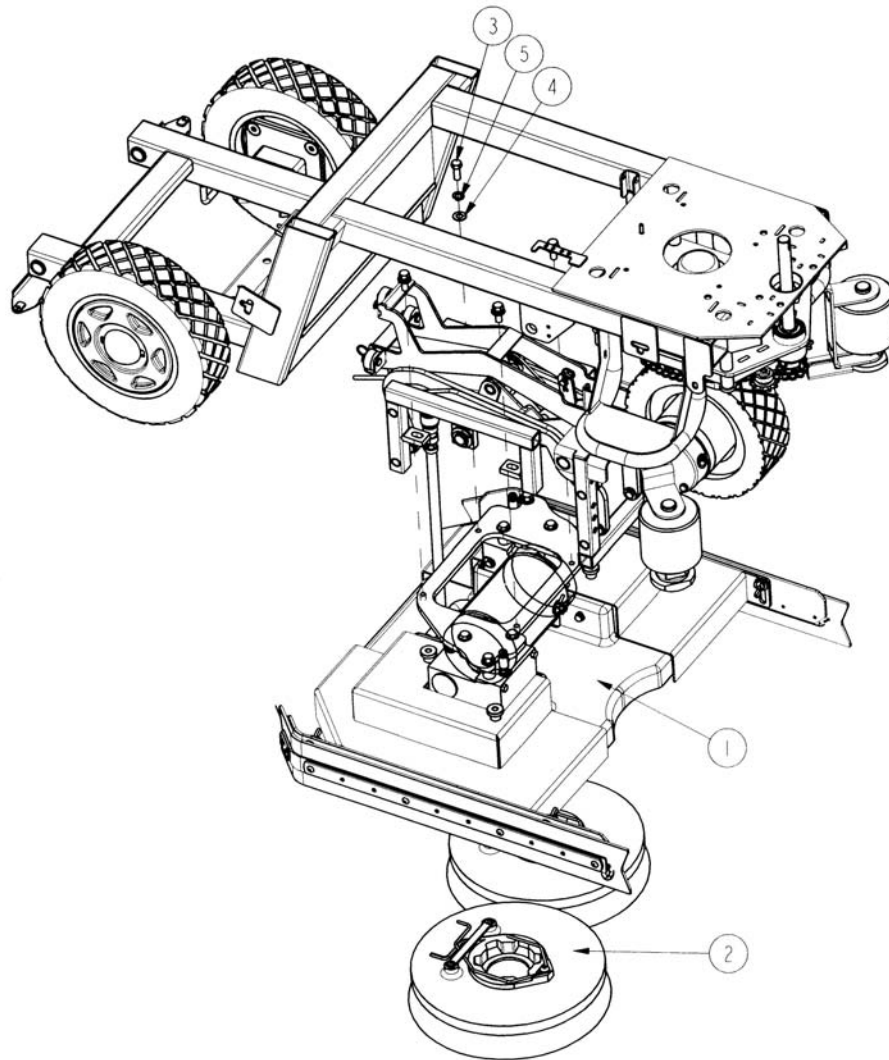

BILL OF MATERIAL			
ITEM	PART NO.	REQ'D	DESCRIPTION
1	241651	1	DISK SCRUBDECK, 26"
2	241630	2	13IN SCRUB BRUSH .022 NYLON
2A	241619	2	BRUSH-13" PWR DRIVE W/PAD HOLDER
2B	241631	2	13" SCRUB BRUSH .028 NYLON
2C	241632	2	13" SCRUB BRUSH DYNASCRUB 500GR
2D	241633	2	13" SCRUB BRUSH POWERSCRUB 120GR
2E	241634	2	13" SCRUB BRUSH NYLOGRIT 80GR
2F	241635	2	13" SCRUB BRUSH STRATAGRIT 46GR
2H	241636	2	13" SCRUB BRUSH 180 GR
3	711242	4	BLT-HEX 3/8 -16X1.00 ZP
4	711515	4	WSR-FLAT .406 X .812 X .0625
5	711546	4	WSR-HELICAL 3/8

OFF AISLE WAND ASSEMBLY (Optional)

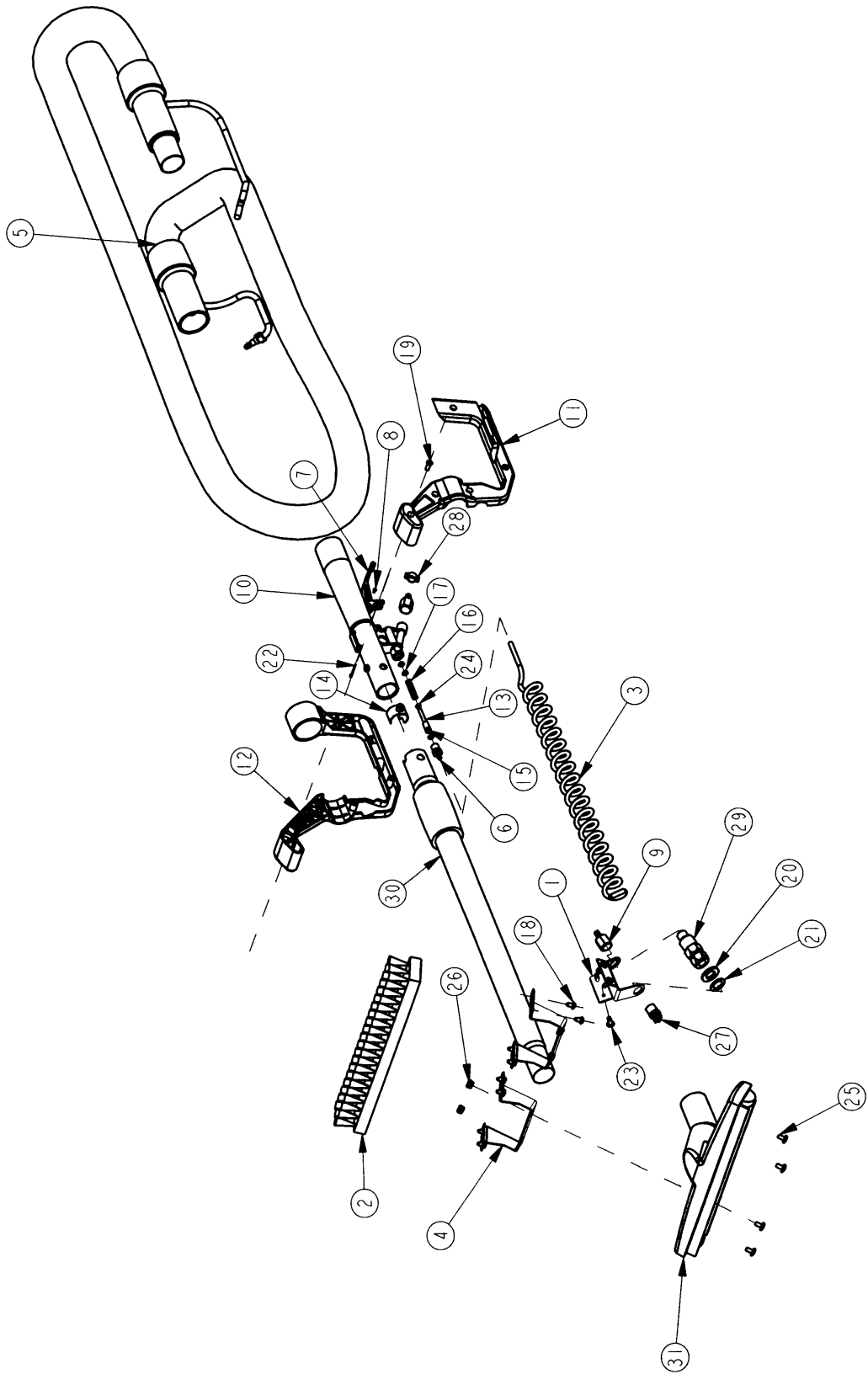

OFF AISLE WAND ASSEMBLY BOM (Optional)

<i>BILL OF MATERIAL 281071</i>			
<i>ITEM</i>	<i>PART NO.</i>	<i>REQ'D</i>	<i>DESCRIPTION</i>
1	100004	1	SPRY JET BKT MC SCRB14GA
2	281044	1	BRUSH 12 X 1.75 X 1.12
3	281045	1	HOSE, SELF-RETRACTING SOLUTION
4	281049	2	BRUSH WAND BRACKET
5	281072	1	HOSE ASSEMBLY, SPRAY/VAC, 2800
6	350280	1	FITTING BRASS 1/8 MPT - 1/8 BARB
7	390053	1	TRIGGER SOL VALVE
8	390063	2	RD HD GRV STUD #2427
9	450218	2	FITTING, BRASS 1/4 FPT, 1/8 BARB
10	450256	1	PICKUP TUBE
11	450257	1	TRIGGER GUARD,LEFT
12	450258	1	TRIGGER GUARD,RIGHT
13	450261	1	VALVE STEM
14	450262	1	LOCKING BUTTON
15	450265	3	O-RING, BROWN
16	450267	1	SPRING SS LC-038D-13
17	450301	1	WASHER, NYLON
18	711116	8	SCR-ST-A 10 X .37 PL
19	711163	5	SCR-HI/LO #10-16 X 1/2
20	711579	1	WSR-FLAT .56 X 1.00 X .100
21	711594	1	WSR-FLAT .56 X .88 X .03
22	711803	1	COTTER PIN-HAIR
23	711903	6	RIVET-POP 3/16"
24	712323	1	WSR-FLT .195 X .281 X .03SS
25	712540	4	SCR-MC 10-24 X .37 SS TH
26	712638	4	NUT, HEX 10-24 SS NYLOC
27	829115	1	VEEJET 1/4"
28	830082	1	HOSE CLAMP 3/8
29	832278	1	1 1/4 WAND END COUPLING
30	832284	1	NUT FOR 832278/832285
31	833384	1	VALVE-BALL TYPE CHECK, 1/4" AB
32	270162MCH	1	TELESCOPING WAND (MACHINED)
33	281048MCH	1	SQUEEGEE NOZZLE - 12" (MACHINED)

PLUMBING DIAGRAM

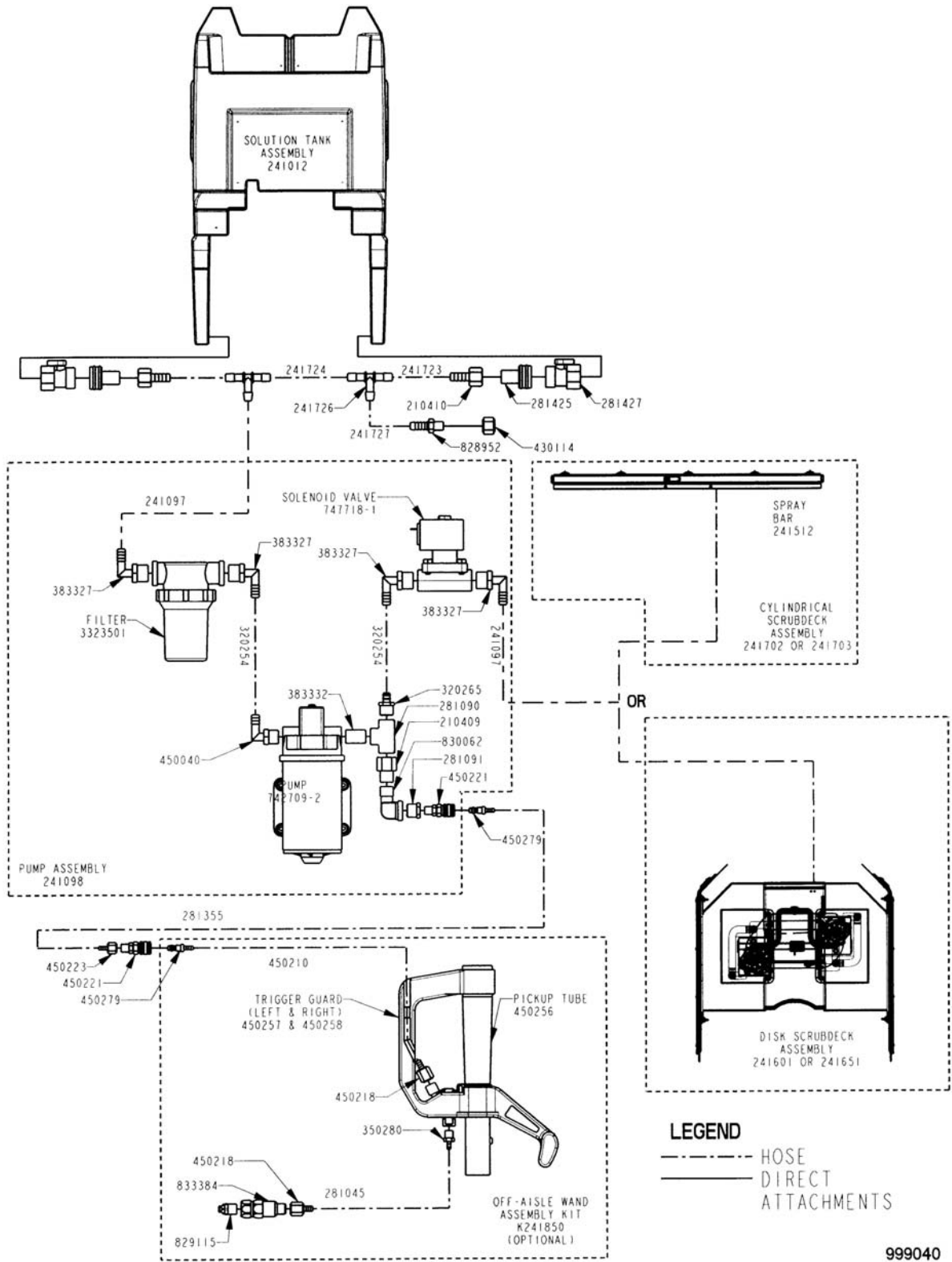

999040

WIRING DIAGRAMS

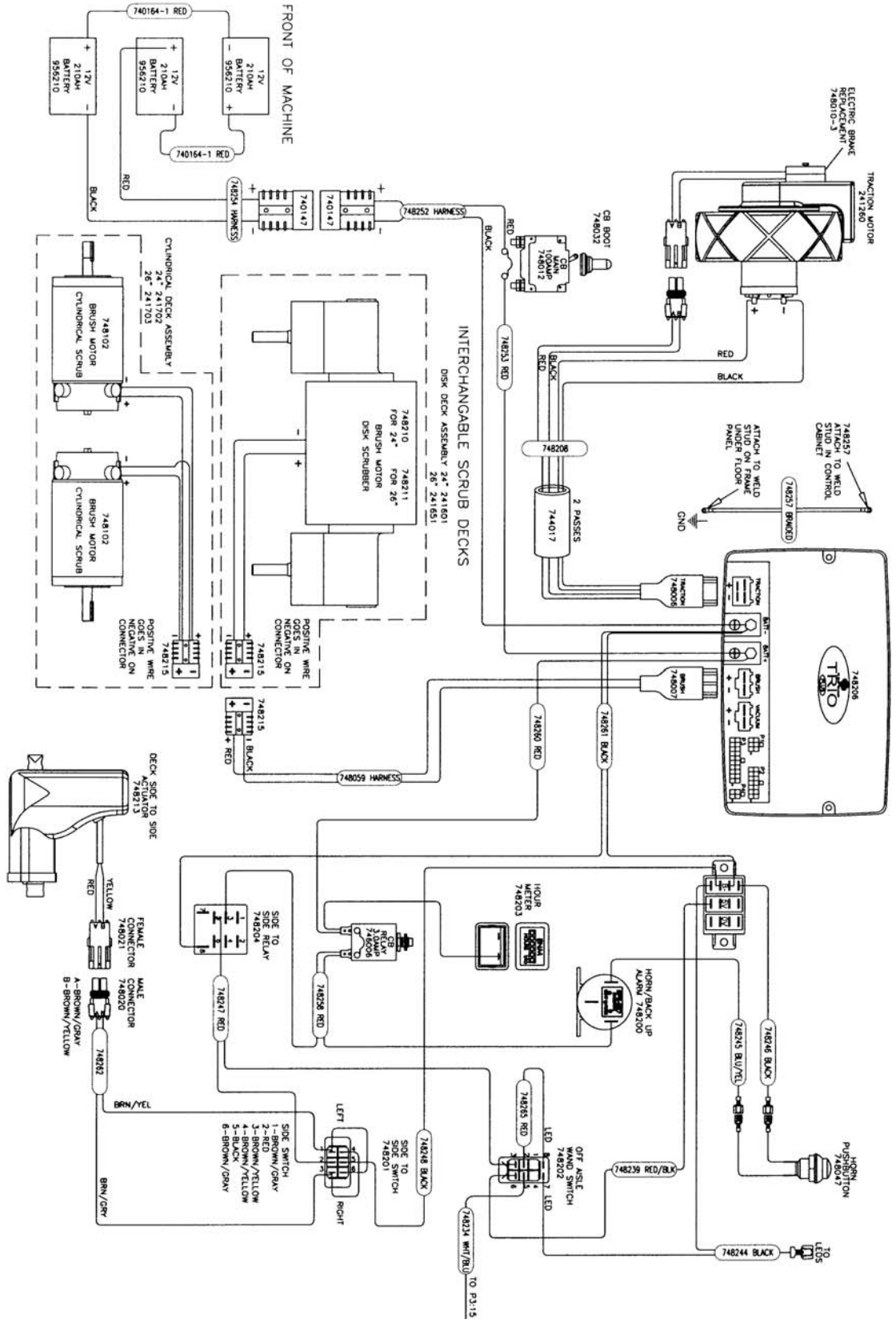

CLAMP ON FERRITE BEAD(748217) IS USED ON WIRES LEADING TO THE STEERING COLUMN.

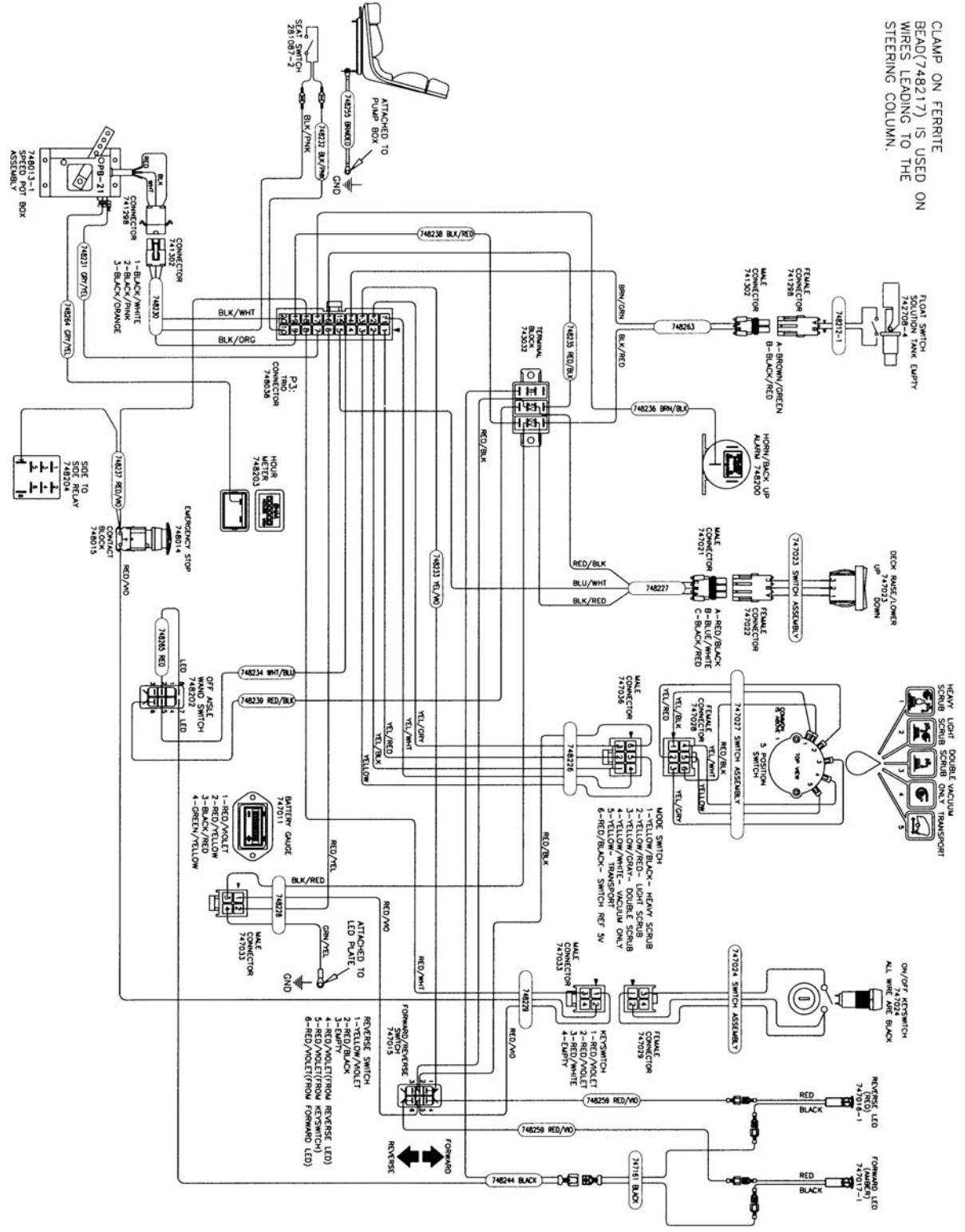

- DIAGNOSTIC CODES : BATTERY GAUGE (7470111)
- 10 BARS FLASHING : HIGH BATTERY VOLTAGE
 - 9 BARS FLASHING : SOLENOID BRAKE FAULT
 - 8 BARS FLASHING : CONTROL SYSTEM FAULT
 - 7 BARS FLASHING : THROTTLE FAULT
 - 6 BARS FLASHING : OFF AISLE WAND SWITCH ON
 - 5 BARS FLASHING : VACUUM MOTOR FAULT
 - 4 BARS FLASHING : FREEWHEEL ACTIVE
 - 3 BARS FLASHING : BRUSH MOTOR FAULT
 - 2 BARS FLASHING : TRACTION MOTOR FAULT
 - 1 BAR FLASHING : LOW BATTERY VOLTAGE
- 10 BARS RIPPLING UP AND DOWN: THROTTLE IS DISPLACED ON START UP

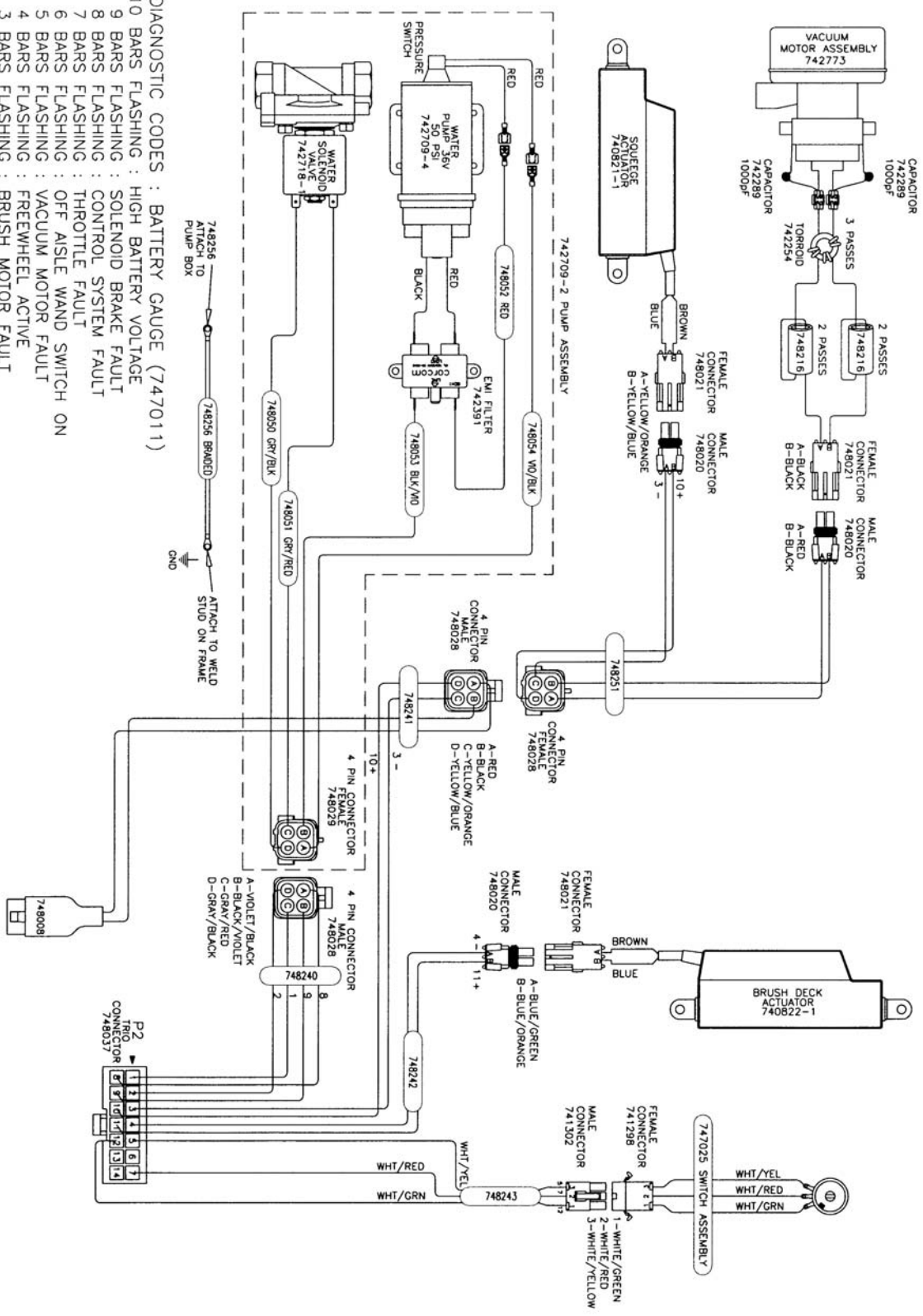

KEY SWITCH

PIN #	HARNESS COLOR	FUNCTION
1	RED/VIOLET	POSITIVE TO LEDS
2	RED/VIOLET	E-STOP-TRIO KSI P3:18
3	RED/WHITE	+V FROM TRIO P3:8
4	EMPTY	-

MODE SELECTOR SWITCH

SWT #	PIN #	COLOR	FUNCTION
1	1	YELLOW/BLACK	HEAVY SCRUB
2	2	YELLOW/RED	LIGHT SCRUB
3	3	YELLOW/GRAY	DOUBLE SCRUB
4	4	YELLOW/WHITE	VACUUM ONLY
5	5	YELLOW	TRANSPORT
C	6	RED/BLACK	SWITCH REF 5V

BATTERY GAUGE

PIN #	COLOR	FUNCTION
1	RED/VIOLET	SWITCHED 36VDC:P3-18
2	RED/YELLOW	SIGNAL: P3-6
3	BLACK/RED	SIGNAL REF 0V
4	GREEN/YELLOW	ESD DISCHARGE

REVERSE SWITCH

PIN #	COLOR	FUNCTION
1	YELLOW/VIOLET	REVERSE
2	RED/BLACK	HIGH SWITCH REF 5VDC
3	EMPTY	-
4	RED/VIOLET	REVERSE LED
5	RED/VIOLET	KEY SWITCH ON
6	RED/VIOLET	FORWARD LED

SIDE TO SIDE SWITCH

PIN #	COLOR	FUNCTION
1	BROWN/GRAY	SIDE ACTUATOR
2	RED	BATTERY 36VDC
3	BROWN/YELLOW	SIDE ACTUATOR
4	BROWN/YELLOW	SIDE ACTUATOR
5	BLACK	BATTERY 0VDC
6	BROWN/GRAY	SIDE ACTUATOR

P2: TRIO CONNECTOR

PIN #	COLOR	FUNCTION
1	GRAY/RED	WATER SOLENOID VALVE
2	GRAY/BLACK	WATER SOLENOID VALVE
3	YELLOW/ORANGE	SQUEEGE ACTUATOR
4	BLUE/GREEN	BRUSH ACTUATOR
5	WHITE/YELLOW	WATER FLOW POTENTIOMETER (SLOW)
6	-	-
7	WHITE/RED	WATER FLOW POTENTIOMETER (WIPER)
8	VIOLET/BLACK	WATER PUMP
9	BLACK/VIOLET	WATER PUMP
10	YELLOW/BLUE	SQUEEGE ACTUATOR
11	BLUE/ORANGE	BRUSH ACTUATOR
12	WHITE/GREEN	WATER FLOW POTENTIOMETER (FAST)
13	-	-
14	-	-

P3: TRIO CONNECTOR

PIN #	COLOR	FUNCTION
1	YELLOW/RED	5 MODE SWITCH: LIGHT SCRUB
2	YELLOW/BLACK	5 MODE SWITCH: HEAVY SCRUB
3	YELLOW	5 MODE SWITCH: TRANSPORT
4	-	-
5	BLUE/WHITE	DECK RAISE/LOWER SWITCH
6	RED/YELLOW	BATTERY GAUGE SIGNAL
7	GRAY/YELLOW	OUR METER
8	RED/WHITE	ON/OFF REF (B+)
9	BLACK/ORANGE	SPEED POTENTIOMETER (SLOW)
10	BLACK/PINK	SPEED POT./SEAT SAFETY SWITCH
11	YELLOW/WHITE	5 MODE SWITCH: VACUUM ONLY
12	YELLOW/GRAY	5 MODE SWITCH: DOUBLE SCRUB
13	YELLOW/VIOLET	REVERSE SWITCH
14	BROWN/GREEN	SOLUTION TANK EMPTY FLOAT SWITCH
15	WHITE/BLUE	OFF AISLE WAND
16	RED/BLACK	HIGH SWITCH REF 5VDC
17	BROWN/BLACK	BACK UP ALARM
18	RED/VIOLET	ON/OFF INPUT-KEY SWITCH
19	BLACK/RED	LOW SWITCH REF 0VDC
20	BLACK/WHITE	SPEED POTENTIOMETER (FAST)

MISCELLANEOUS

COLOR	FUNCTION
RED	BATTERY 36VDC
BLACK	BATTERY 0VDC
RED/BLACK	HIGH SWITCH REF 5VDC
BLACK/RED	LOW SWITCH REF 0V
BLUE/YELLOW	HORN

LIMITED WARRANTY

Minuteman International, Inc. warrants to the original purchaser/user that this product is free from defects in workmanship and materials under normal use and service for a period of three years from date of purchase. In addition, Minuteman International, Inc. will, at its option, honor labor warranty claims for the first 36 months from date of sale, provided such claims are submitted through and approved by factory authorized repair stations. Minuteman International, Inc. will, at its option, repair or replace without charge, except for transportation costs, parts that fail under normal use and service when operated and maintained in accordance with the applicable operation and instruction manuals.

This warranty does not apply to normal wear, or to items whose life is dependent on their use and care, such as belts, cords, switches, hoses, rubber parts, electrical motor components or adjustments. Parts not manufactured by Minuteman International, Inc. such as engines, batteries, battery chargers, hydraulic pumps, and tires are covered by and subject to the warranties and/or guarantees of their manufacturers. Please contact Minuteman International, Inc. for procedures in warranty claims against these manufacturers.

Special warning to purchaser -- Use of replacement filters and/or pre-filters not manufactured by Minuteman International, Inc. or its designated licensees, will void all warranties expressed or implied.

A potential health hazard exists without exact original equipment replacement.

All warranted items become the sole property of Minuteman International, Inc. or its original manufacturer, whichever the case may be.

Minuteman International, Inc. disclaims any implied warranty, including the warranty of merchantability and the warranty of fitness for a particular purpose. Minuteman International, Inc. assumes no responsibility for any special, incidental or consequential damages.

This limited warranty is applicable only in the U.S.A. and Canada, and is extended only to the original user/purchaser of this product. Customers outside the U.S.A. and Canada should contact their local distributor for export warranty policies. Minuteman International, Inc. is not responsible for costs or repairs performed by persons other than those specifically authorized by Minuteman International, Inc. This warranty does not apply to damage from transportation, alterations by unauthorized persons, misuse or abuse of the equipment, use of non-compatible chemicals, or damage to property, or loss of income due to malfunctions of the product.

If a difficulty develops with this machine, you should contact the dealer from whom it was purchased.

This warranty gives you specific legal rights, and you may have other rights which vary from state to state. Some states do not allow the exclusion or limitation of special, incidental or consequential damages, or limitations on how long an implied warranty lasts, so the above exclusions and limitations may not apply to you.

Minuteman[®]

World Headquarters
Minuteman International, Inc.
111 South Rohlwing Road
Addison, Illinois 60101

(630) 627-6900
FAX (630) 627-1130

Minuteman Canada, Inc.
2210 Drew Road
Mississauga, Ontario
L5S 1B1

(905) 673-3222
FAX (905) 673-5161

Form 987597
Printed in U.S.A.

REV A 2/05